



KONGSBERG

Instruction manual

HPR 400P series

Portable Acoustic Positioning System

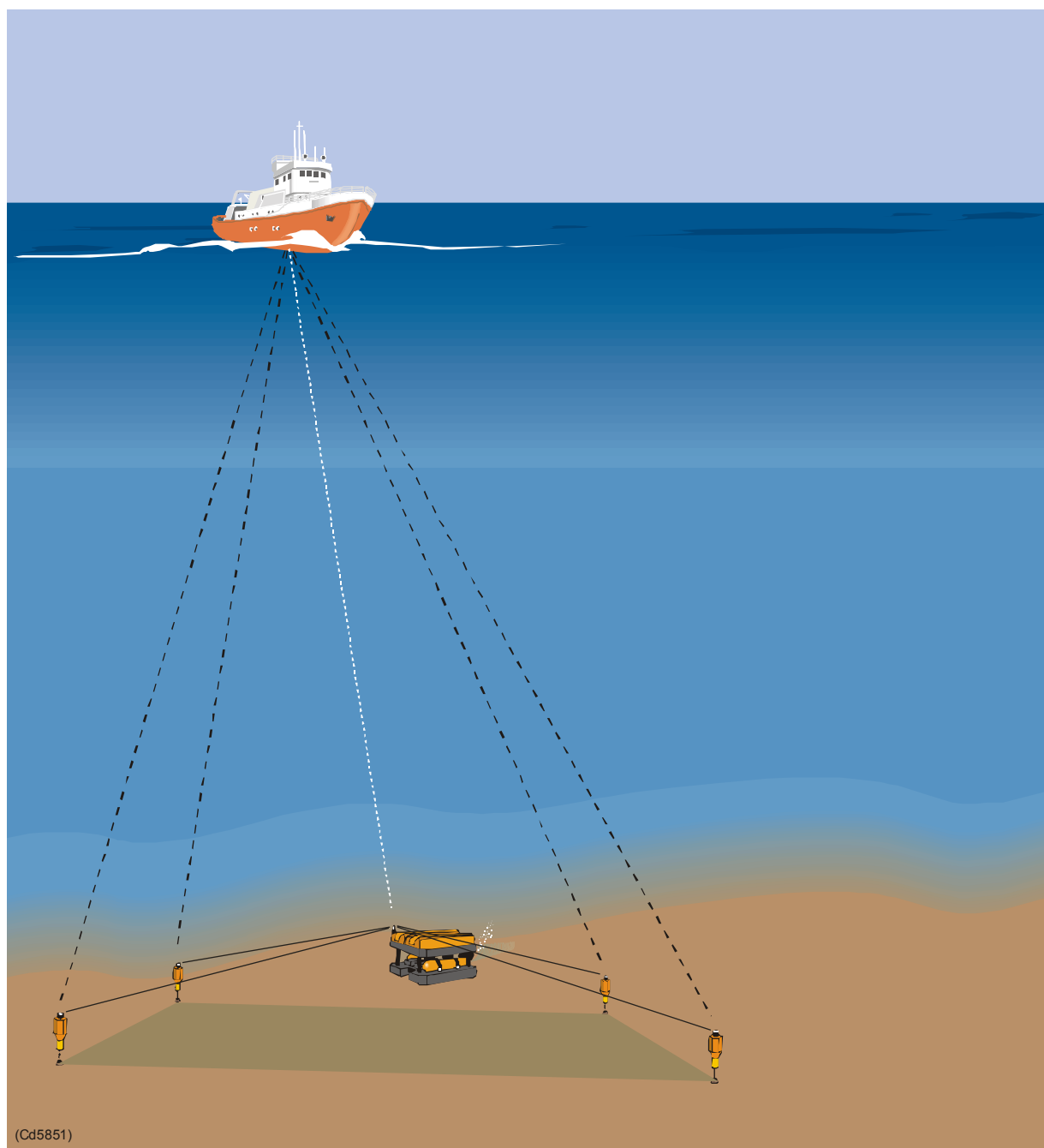

HPR 400P series

Portable Acoustic Positioning System

Instruction manual

Note

Kongsberg Simrad AS makes every effort to ensure that the information contained within this document is correct. However, our equipment is continuously being improved and updated, so we cannot assume liability for any errors which may occur.

Warning

The equipment to which this manual applies must only be used for the purpose for which it was designed. Improper use or maintenance may cause damage to the equipment or injury to personnel. The user must be familiar with the contents of the appropriate manuals before attempting to install, operate or maintain the equipment.

Kongsberg Simrad AS disclaims any responsibility for damage or injury caused by improper installation, use or maintenance of the equipment.

Copyright

© 2003 Kongsberg Simrad AS

The information contained within this document remains the sole property of Kongsberg Simrad AS. No part of this document may be copied or reproduced in any form or by any means, and the information contained within is not to be communicated to a third party, without the prior written consent of Kongsberg Simrad AS.



Sections

This manual describes the maintenance and set-up of the HPR 400P Hydroacoustic Positioning Reference system. The maintenance philosophy is based on the system's built-in test equipment (BITE) for self diagnostics. The maintenance technician is only expected to replace modules and units.

1 Introduction

Introduction to the manual.

2 HPR 400P System description

This section describes the HPR 400P system.

3 Installation and set-up

This section includes the general procedure for connecting and setting-up the system.

4 Maintenance

This section describes the maintenance which the operator is expected to be able to perform. Detailed mechanical and electrical maintenance should be performed by a specialist engineer.

5 HPR 400 Transceiver Unit

This section gives a technical description of the HPR 400 Transceiver Unit, using text and block diagrams. The section includes disassembly and reassembly instructions.

6 Technical specifications

This section presents the technical specifications for the complete system.

7 Spare parts

This section contains a list of the spare parts available for the HPR 400 Portable system.

8 Drawings

This section contains drawings of the system and transducers.

9 Index

Main index.

Additional manuals

Compact PC manuals

Separat manual supplied with the potable unit. This is not a Kongsberg Simrad document.

Remarks

References

Further information about the HPR 400P system may be found in the following manuals:

- APOS Instruction manual

The reader

This maintenance manual is intended to be used by a trained maintenance technician or engineer, with experience of electronic and digital circuitry, computers and electromechanical design. The level of information is based on Kongsberg Simrad's maintenance philosophy: The onboard technical personnel shall, with the help of the documentation and the system's built-in test functions, be able to identify malfunctions, locate the fault, and replace major parts, modules and components on the "Line Replaceable Unit (LRU)" level. He/she will however not attempt to repair the LRUs.

Note

This manual includes sections that may be revised individually. In the event of a revision to any part of this manual, this "Cover and Contents" section will be replaced.

This manual is issued according to a registered distribution list. In the event of changes to this manual, only authorized copies with copy numbers will be updated.

Contents

INTRODUCTION	1
Overview	1
List of abbreviations	1
SYSTEM DESCRIPTION	2
Overview	2
System units	2
HPR 400 portable systems	2
HPR 410P/418P	3
HPR 408P surface system	4
HPR 408P subsea system	5
Portable system	6
HPR 400 Transceiver Unit	7
Operator station	7
Available systems	7
Transducers	8
Overview	8
PMT 301 Portable Mini Transducer	9
Dunking transducer	9
Standard transducer (wide/medium)	9
Narrow beam transducer (wide/narrow)	9
External sensors (options)	9
Vertical Reference Unit (VRU)	9
Gyro	9
INSTALLATION AND SET-UP	10
Overview	10
System set-up	11
General	11
Cable connections	11
Transducers	12
Getting started	13
Modes	13
Cables and connectors	14
General	14
Internal cables	14
External cables	15
Connections	16
Connectors	16
HPR 400 Transceiver Unit connectors	16
Compact PC (Operator Station) connectors	18

Standard cables	19
Serial line cables	19
Standard configuration	19
Cable A	19
Transceiver unit - responder cables J	19
Transceiver Unit pin allocations	21
Introduction	21
Serial 1	21
Serial 2	21
Serial 3	21
Serial 4	22
Serial 5	22
Serial 6	22
Parallel	22
Analogue I/O	23
Gyro/syncro	23
Responder 1 - 4	24
Transducers 1 and 2	24
Transducers 3 and 4	24
Computer pin allocations	25
Introduction	25
Com 1, 2 and 3	25
LPT 1	25
VGA	26
MAINTENANCE	27
General	27
Maintenance philosophy	27
Preventive maintenance	27
Corrective maintenance	28
Tools	28
Transceiver unit	28
Operator station	28
Alarm and event messages	29
Winch unit	30
General	30
Cable drum	30
Transducer	31
General	31
Cleaning the transducers	31
Replacement of the transducer	31
Replacement of transceiver unit parts	32
Overview	32

Replacement of circuit boards and software	32
Removal of circuit boards	32
Software replacement	33
Remove a unit / board	34
Insertion	34
To remove the backplane	34
Replacement of the backplane	35
Replacement of circuit boards	35
Fuses	36
Location	36
Replacement	37
HPR 400 TRANSCEIVER UNIT	38
Design	38
External connections	38
Power supply	38
Maintenance	38
Theory of operation	39
Introduction	39
Navigation	39
Telemetry	39
Circuit board identification and main functions	40
Internal layout	42
Backplane	44
InputM	46
Connections	46
Test points	46
Analogue digital converter (ADCM)	48
Board description	48
Digital signal processor (DSPM 50)	50
Transmitter (TXM)	52
“Powerbox” AC power supply	54
Control Processor Unit (CPU EX)	56
Input/output board (IO/M)	58
Responder controller (RPC) board (option)	60
DC power supply (DC - PWR)	62

TECHNICAL SPECIFICATIONS	64
SSBL Accuracy	64
LBL accuracy	64
Range capabilities	66
HPR 400 portable unit	67
HPR 400 Transceiver Unit	68
Compact PC (Operator station)	69
Transducers	70
General	70
PMT 301 - Portable Mini Transducer	70
Standard MF (wide/medium beam) transducer	71
MF (wide/narrow beam) transducer	71
LF (wide beam) transducer	71
Dunking transducers	72
RTD 333 - ROV Transducer	73
SPARE PARTS	74
Overview	74
HPR 400 Transceiver unit	75
Fuses	75
Portable PC	76
Standard transducers	76
Dunking transducers	76
RTD 333 - ROV Transducer	76
DRAWINGS	77
Overview	77
Cables and interconnections	77
Standard transducers	77
Dunking transducers	77
Miscellaneous	77
MAIN INDEX	92

Document logistics

Rev	Date	Written	Checked	Approved
A	06.12.00	GM	RA	JEF
B	15.02.02	GM	EB	JEF
C	06.03.03	GM	EB	JEF
D				
E				
F				
G				

(The original signatures are recorded in the company's logistic database.)

Rev	Comments
A	Original issue.
B	Technical data updated. Reduced PCBs information. Contents reorganised. New layout.
C	Implemented portable system with HPR 400 Subsea unit and technical specifications for the Inclinometer. Updated and reorganised technical specifications. Minor corrections in the text. Ref. EM 857-164388C.
D	

To assist us in making improvements to the product and to this manual, we would welcome comments and constructive criticism. Please send all such - in writing or by e-mail - to:



Kongsberg Simrad AS
 Documentation Department
 P.O.Box 111
 N-3191 Horten
 Norway

or e-mail:

simrad.documentation@simrad.com

Blank page

INTRODUCTION

Overview

This document describes the Kongsberg Simrad HPR 400 Portable Underwater Positioning and Navigation Systems using the following operating modes:

- Super Short Base Line (SSBL)
- Long Base Line (LBL)
- Combined Long and Super Short Base Line (LSSBL)

List of abbreviations

APOS	Acoustic Positioning Operator Station
DGPS	Differential Global Positioning System
HiPAP	High Precision Acoustic Positioning
HPR	Hydroacoustic Position Reference
HPR 400S	Hydroacoustic Positioning Reference Subsea System
LBL	Long Base Line
LF	Low Frequency
MF	Medium Frequency
MPT	Multifunction Positioning Transponder
N/A	Not Applicable
ROV	Remotely Operated Vehicle
SSBL	Super Short Base Line
TP	TransPonder
TU	Transceiver Unit

SYSTEM DESCRIPTION

Overview

A **HPR 400P system** is assembled in a rugged, splash-proof, shock resistant and "all in one" portable cabinet.

The portable cabinet is equipped with strong carrying handles and has detachable covers in front and rear.

Together with applicable software and a selection of transducers, the systems are easy to move by simply interfacing the applicable transducer to the back-plane of the HPR portable unit.

The transducer may be deployed from any vessel or platform.

All systems are based around the same portable electronic cabinet, but software and transducer interfaces will vary.

All the HPR 400P systems can be directly interfaced to a Differential Global Positioning System (DGPS) receiver, making it possible to give transponder position, Super Short Base Line (SSBL) or vessel position, Long Base Line (LBL) in UTM coordinates.

System units

A complete HPR portable system comprises:

- Operator station (Compact PC)
- HPR 400 transceiver Unit
- Transducer with cable
- Transponder(s)

HPR 400 portable systems

The Kongsberg Simrad HPR 400 portable systems available are:

- **HPR 410P** - Portable SSBL system, with portable transducer.
- **HPR 408P:**
 - Portable LBL system with dunking transducer.
 - Portable LBL system with subsea transceiver (HPR 400S).
- **HPR 418P** - Portable combined LBL/SSBL system with Portable Mini Transducer.

HPR 410P/418P

The HPR 410P and 418P systems, are normally delivered with a **transducer** and cable.

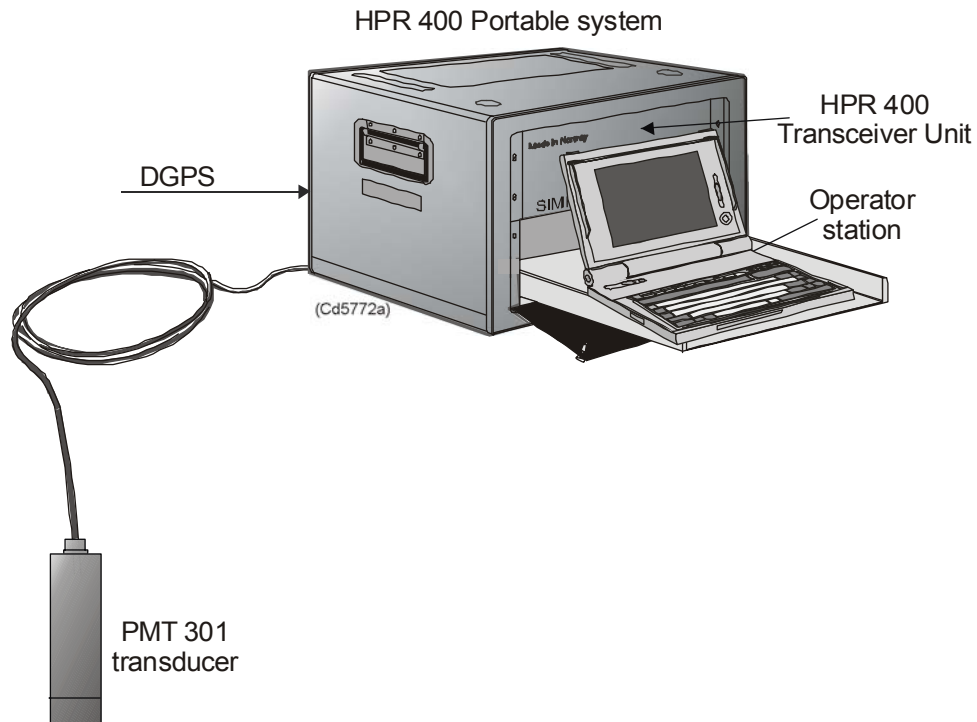

Figure 1 HPR 410 / 418 Portable system

HPR 408P surface system

This HPR 408P system is normally delivered with a **transducer** and a cable with cable drum.

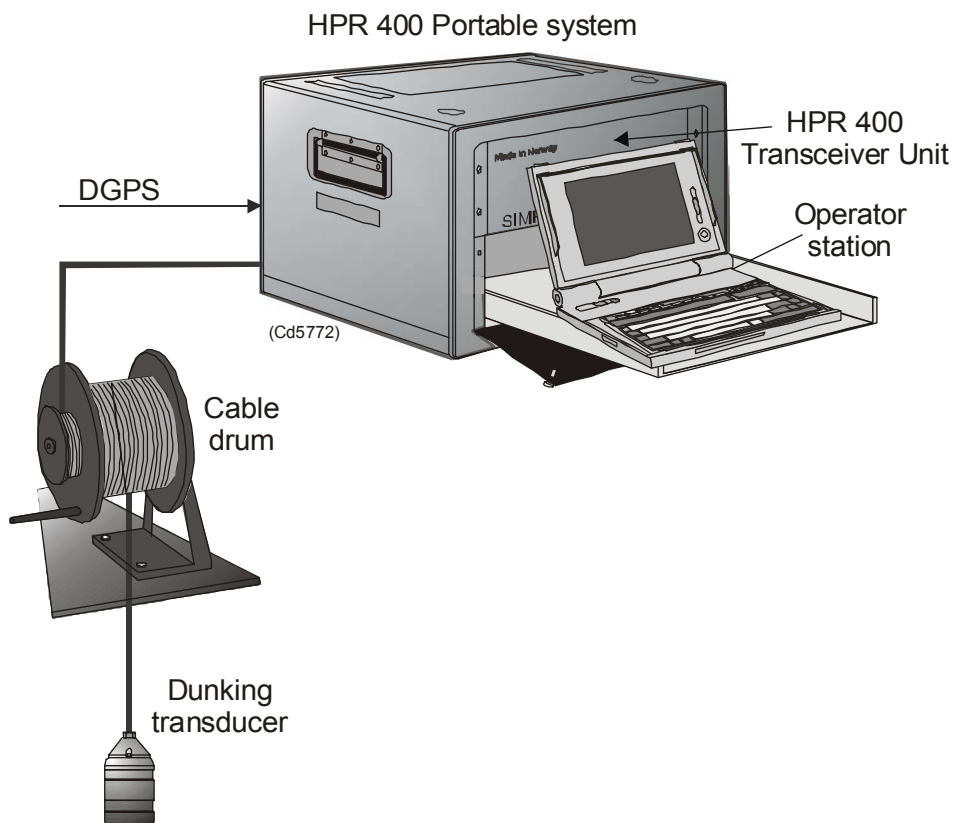

Figure 2 HPR 408Portable system

HPR 408P subsea system

This HPR 408P system, is delivered with a subsea transceiver and transducer.

Note

The Subsea Transceiver Unit and dedicated transducer are described in the HPR 400S Instruction manual.

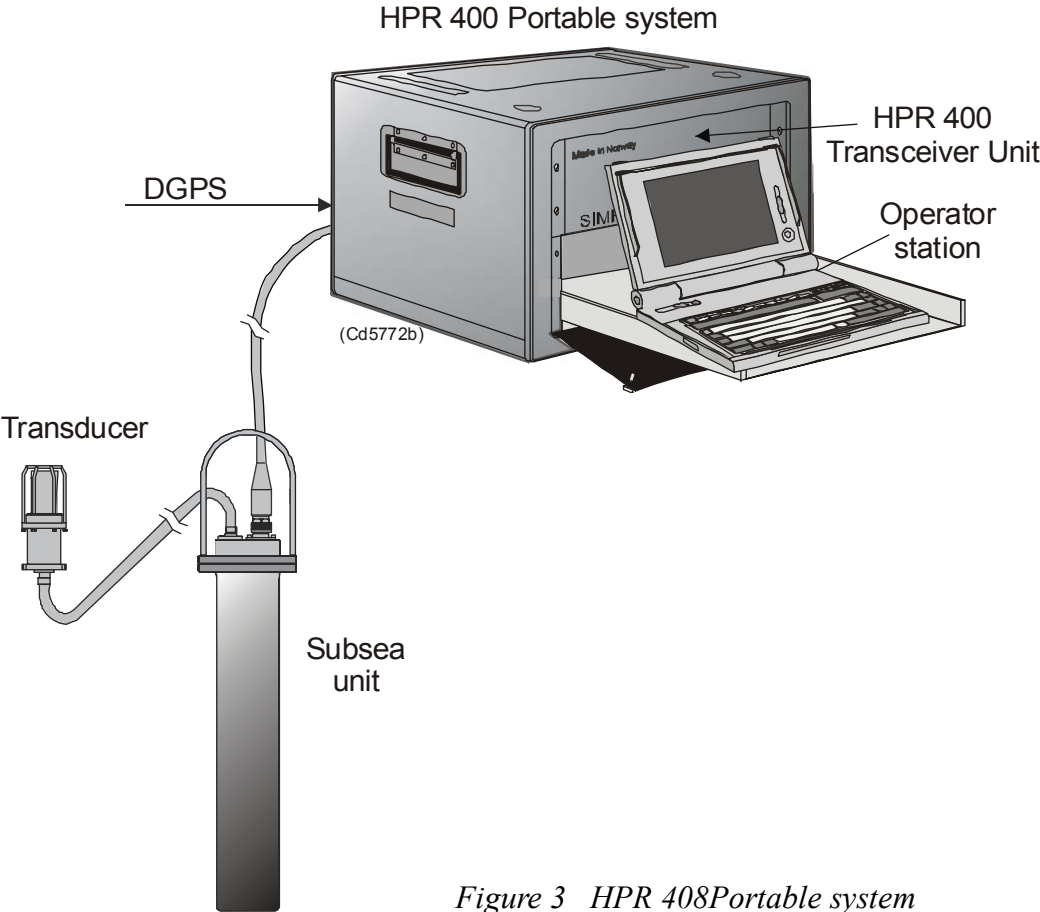

Figure 3 HPR 408Portable system

Portable system

The HPR 400 Portable system comprises:

- HPR 400 Transceiver Unit
- Operator station (Compact PC)



Figure 4 Portable cabinet

As shown on the figure below, the connectors for all interfaces are made easily available from the rear.

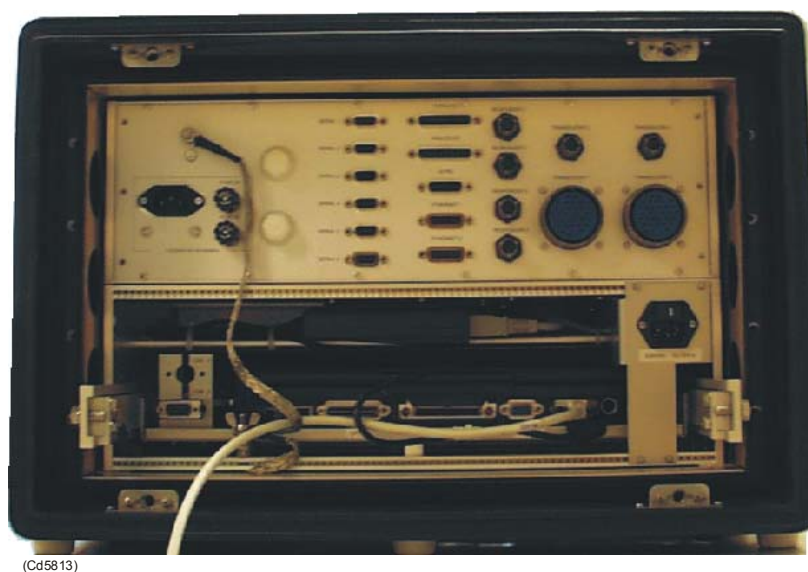

Figure 5 Portable cabinet - rear side

HPR 400 Transceiver Unit

The Transceiver is the acoustic signal processor with transmitter and receiver electronics and software. It processes the acoustic signals, calculates the transponder position(s) and the acoustic telemetry data, and sends the information to the portable PC where it is presented on the display.

- The transceiver has interfaces for the transducer(s), a gyro and a pitch/roll sensor.
- It can operate up to four transducers with up to 56 + 14 transponders simultaneously.
- The acoustic telemetry functions are also controlled from this unit, using the same transducers.

Operator station

The portable computer contains the APOS (system) software.

→ *For more information about the Portable PC, refer to separate manual.*

Available systems

HPR 410P - SSBL

The **HPR 410P** - is the SSBL system. Together with dedicated SSBL software and the Portable Mini Transducer (PMT 301), a single compact transducer unit, it is applicable as a stand-alone underwater navigation system.

- The calculation of position is based on range, vertical and horizontal angle measurements, giving three-dimensional transponder positions relative to the system's transducer.
- The beam-pattern of the PMT 301 transducer is omni-directional and will cover the whole 160° hemisphere below the vessel. This means that the system has high sensitivity in all planes, both for transponder signals and for noise coming in. The system will therefore be more sensitive to noise from the vessels propellers than systems with more directive beam pattern. This is why we do not recommend this transducer for critical operations like for instance being a reference to a DP system. For such operations, optional beam-forming transducers are available.

- The transducer is supplied with an underwater connector and a handy mounting bracket, which allows a very easy installation to any pole or shaft over the side of a vessel. The transducer and the bracket comes also in a robust carrying case.
- A built-in roll and pitch sensor, designed around highly accurate electronic inclinometers is in the transducer, and enables the system to automatically compensate for any vertical misalignment of the transducer/transducer-pole, as well as compensation of roll and pitch movements.

HPR 408P - LBL

The **HPR 408P** - is a stand-alone portable LBL system. By using LBL software and dedicated over-the-side (Dunking Transducer), the system becomes a surface system for any LBL or telemetry application.

The HPR 408P system can also be delivered with a subsea transceiver (HPR 408S) connected to the Portable unit, and this will be suitable for Remotely Operated Vehicle (ROV) LBL positioning, as well as for any other subsea module positioning requiring LBL accuracy's. Both «systems» will then be operated from the same Operator station.

With their comprehensive manuals and self-explanatory operating menu, the LBL systems are considered to be very user friendly.

HPR 418P - combined LBL and SSBL

The **HPR 418P** - is a powerful portable underwater positioning system. It is capable of solving most underwater positioning applications. The system is a combination of the HPR 408P and HPR 410P, and can work in a combined mode using a SSBL transducer.

For details, see the HPR 408P and HPR 410P information above.

- *For more information on the HPR 400S system, refer to the HPR 400S Instruction manual.*
 - For APOS start-up, refer to the APOS Instruction manual.
 - For APOS operation, refer to the APOS On-line help.

Transducers

Overview

Several SSBL and LBL transducer types are available, and can be supplied with the system.

A standard transducer mounted on a hull unit may also be used if required. This would enable the portable system to be used as an emergency system if the standard system should develop a fault. These are not described in this manual.

PMT 301 Portable Mini Transducer

The HPR 410P is normally delivered with the PMT 301 Portable Mini Transducer. This transducer can be used for SSBL and LBL operation.

Dunking transducer

Several types of dunking transducers are available. These are used for LBL or telemetry operation.

A portable transducer is connected onto a 70 m transducer cable which is held on a cable drum. The transducer must be lowered to a depth well below the lowest point of the vessel's hull. The "free end" of the cable must be connected to the transceiver unit.

Standard transducer (wide/medium)

This transducer can be used for LBL and SSBL operations. The HPR 400 system then requires an external VRU.

Narrow beam transducer (wide/narrow)

This transducer can be used for LBL and SSBL operations. The HPR system then requires an external VRU.

External sensors (options)

Vertical Reference Unit (VRU)

A Vertical Reference Unit (VRU) can be interfaced to the HPR 400P transceiver if required. The system can thereby automatically compensate for the vessel's roll and pitch movements. The HPR 400 system can use the same VRU as the Dynamic Positioning (DP) system (if one is fitted).

The MPT301 transducer contains a built-in roll/pitch sensor (Shaevitz).

Gyro

A number of different gyro types can be interfaced to the HPR 400 Portable System transceiver if required (syncro or serial).

INSTALLATION AND SET-UP

Overview

This section describes the installation and set-up procedures for the HPR 400P system. A description of the cables and the interconnections between the units is also included.

System set-up

General

Place the HPR 400P unit on a reasonably level and stable surface, and proceed as follows:

- 1 Remove the front and rear covers of the case.
 - You now have access to the Operator Station (Compact PC) and the Transceiver Unit (TU).
- 2 Extract the Operator Station.

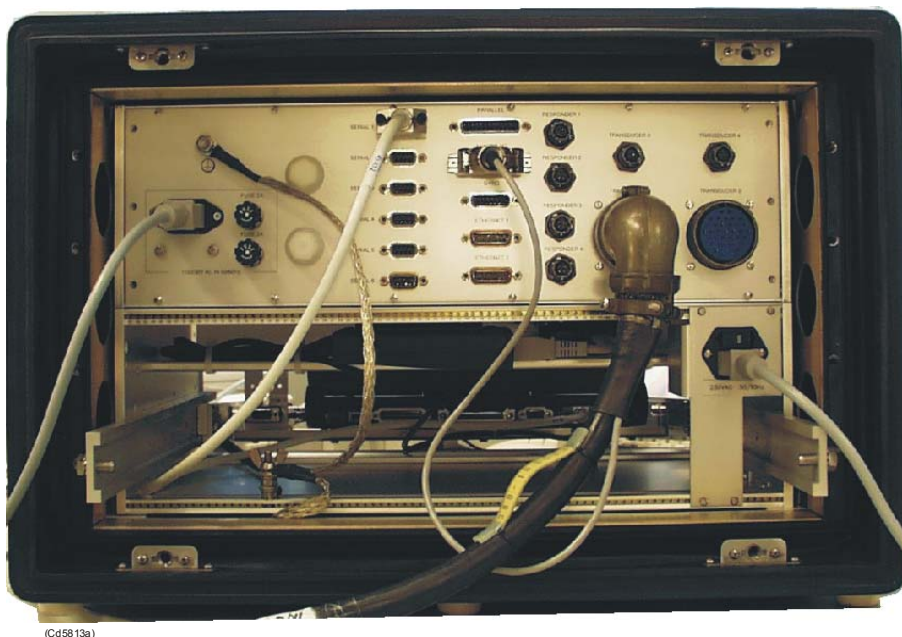

(Cd5813a)

Figure 6 HPR 400 Transceiver Unit - rear side, showing connections for a MPT 301 transducer

Cable connections

- 1 Check the portable unit internal connections.
- 2 Connect the required TU interface cables
 - Standard cables:
 - Transducer cable(s)
 - 230 Vac supply

- Options
 - Gyro compass
 - Vertical reference sensor (VRU)
(Included in the PMT 301 transducer cable)
 - Serial line to external computer
 - Responder(s) (requires an optional responder board)
 - External VGA monitor
 - Printer
 - Depth

Note

Only the standard cables are described in this document.

→ *Refer to section on page 15*

Transducers

PMT 301 Portable Mini Transducer

The portable unit must be placed close to the ships' railing to ensure correct use of the transducer.

- 1 Lower the transducer into the sea.
- 2 When lowered into position, the cable must be securely fastened to the ship railing.
- 3 Ensure no sharp edges can cut the cable.

Dunking transducer

The portable unit must be placed close to the ships' railing to ensure correct use of the dunking transducer.

- 1 Lower dunking transducer is lowered into the sea.
 - Two persons should participate. One person lowering the cable by hand, the other loosening the cable from the cable drum
 - The hand crank on the drum is only for helping the cable on/off, as the transducer is too heavy for crank handling only.
- 2 When fully lowered, the drum locking pin should be tightened. In addition, the cable must be securely fastened to the ship railing. Ensure no sharp edges can cut the cable.

Getting started

To switch on the HPR 400P, perform the procedure below:

- 1 Switch on the transceiver unit using the switch on the front panel.
- 2 Switch on the computer using the *Power on* switch.
- 3 Wait for the system to run up and boot. Once the **Positioning** picture is displayed on the screen, the system is ready for use.

→ *Refer to the APOS Instruction manual/APOS On-line help for details on operating the system.*

Modes

Standby mode

The **Standby** mode is a condition in which the PC reduces its power usage by switching off most of its components when it has not been used for a set period of time. This condition is practical if you should leave the PC running unattended for short periods.

The mode can be initiated by pressing the **Standby** mode button. When you exit the mode (by pressing the button again) the information will be brought back to the display. With a fully charged battery, the PC can remain in the **Standby** mode for up to 120 hours.

Dormant mode

The **Dormant** mode is a condition in which the computer stores all the information in the system memory, on the hard disk.

When you switch power on to the PC, all the information is returned to the system memory, such that the computer returns to the point in the program/document at which the dormant mode was initiated. The computer can remain in the **Dormant** mode for an unlimited period, as long as the battery is not discharged.

Cables and connectors

General

All standard cables delivered with the system are indicated in the figure below.

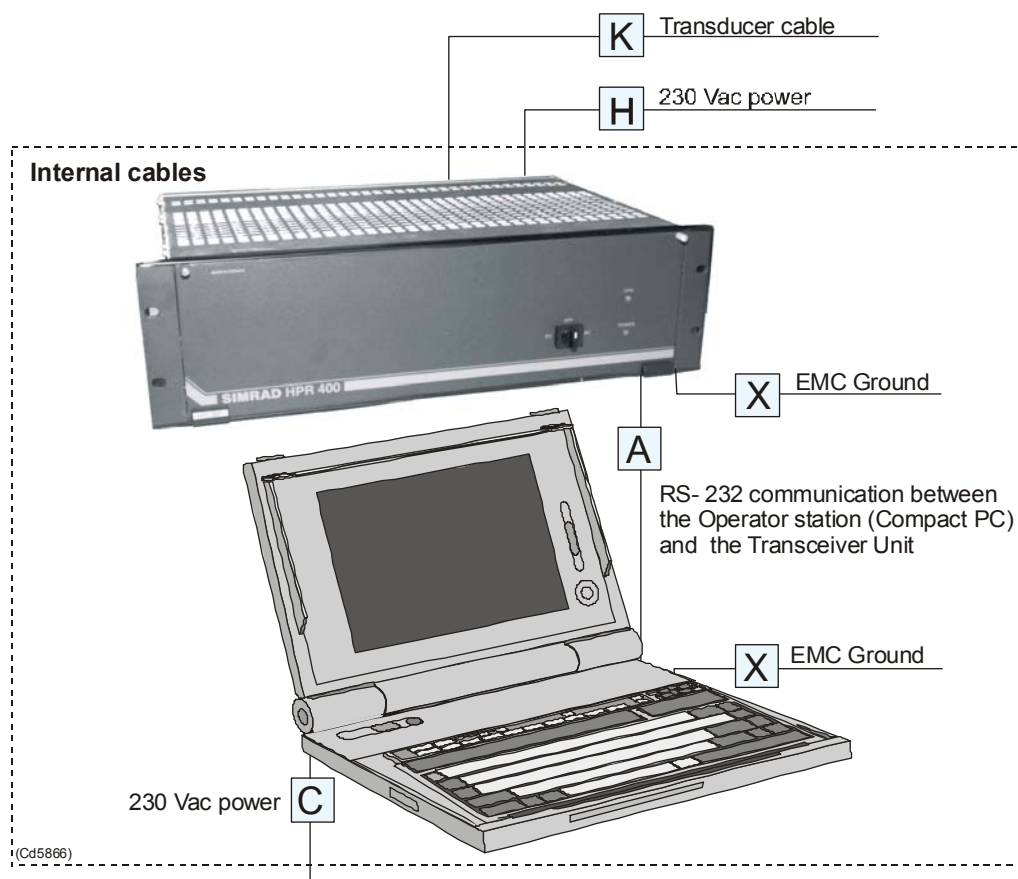

Figure 7 Standard cables for a HPR 400 Portable system

Internal cables

Cable A

Communication between the HPR 400 Transceiver Unit and the Operator station. RS-232 Serial line cable

- Included with the delivery.
- 3 x 2 / 0.5 mm², overall braided screen, 60 V.
- RFI screen must be connected to the plug housing.

Cable X Braided grounding cable to connect the unit to EMC ground

- Included with the delivery (Kongsberg Simrad part no.649-096720).
- 2 x 7 mm.
- Maximum length: 1 m.

External cables

Cable C 230 Vac power supply to the Compact PC

- Included with the delivery.
- 3 x 1 / 1.5 mm² with ground as separate conductor, 750 V.
- Maximum length: No practical limits.

Cable H 230 Vac power supply to the transceiver unit

- Included with the delivery.
- 3 x 1 / 1.5 mm² with ground as separate conductor, 750 V.
- Maximum length: No practical limits.

Cable K Transducer cable from the transceiver unit to the transducer

- Included with the delivery.
- System specified.

Connections

Connectors

Both the HPR 400 Transceiver Unit and the computer have a number of rear-mounted connectors. These can be used to connect a variety of different units and systems into the HPR 400P.

HPR 400 Transceiver Unit connectors

All connections to and from the HPR 400 Transceiver Unit are made on the connection panel on the rear of the unit. All connectors are male except where stated female.

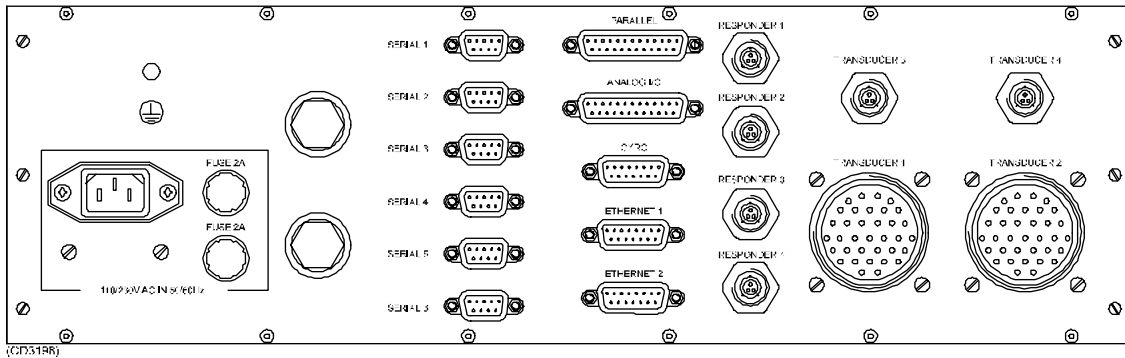

Figure 8 Connectors on the HPR Transceiver Unit's rear panel

The transceiver unit holds the following connectors and fuses used with a HPR 400 P system (top to bottom, left to right when looking at the rear panel):

- 1 Standard 3-pin, 230 Vac, 50/60 Hz mains power in.
- 2 Fuse, 230 Vac, 2 A.
- 3 Fuse, 230 Vac, 2 A.
- 4 9-pin D-connector for Serial line 1.
 - This connector is used to communicate with the PC.
- 5 9-pin D-connector for Serial line 2.
 - This connector is not used with the HPR 400 P.
- 6 9-pin D-connector for Serial line 3.
 - This connector is used to connect a serial line gyro, or any of the following Vertical Reference Unit types: MRU or Seapath.
- 7 9-pin (Seatex) D-connector for Serial line 4.
 - This connector is not used with the HPR 400 P.
- 8 9-pin D-connector for Serial line 5.
 - This connector is not used with the HPR 400 P.

- 9** 9-pin D-connector for Serial line 6.
 - This connector is not used with the HPR 400 P.
- 10** 25-pin D-connector for Parallel input.
 - This connector is not used with the HPR 400 P.
- 11** 25-pin D-connector for Analogue input/output.
 - Piro 40 $\pm 15^\circ$
 - Piro 40 $\pm 90^\circ$
 - PMT Accustar $\pm 60^\circ$
 - Shaevitz $\pm 4.5^\circ$
 - MRU $\pm 20^\circ$
- 12** 15-pin D-connector for Gyro input (syncro)
- 13** 3-pin Amphenol connector for Responder 1. (Optional)
- 14** 3-pin Amphenol connector for Responder 2.
- 15** 3-pin Amphenol connector for Responder 3.
- 16** 3-pin Amphenol connector for Responder 4.
- 17** 3-pin Amphenol connector for Transducer 3.
 - This transducer connector is used with dunking transducers.
- 18** 3-pin Amphenol connector for Transducer 4.
 - This transducer connector is used with dunking transducers.
- 19** 35-pin Amphenol connector for Transducer 1.
 - This transducer connector is used with PMT 301, SSBL MF medium, SSBL MF narrow and SSBL LF medium transducers.
- 20** 35-pin Amphenol connector for Transducer 2.
 - This transducer connector is used with PMT 301, SSBL MF medium, SSBL MF narrow and SSBL LF medium transducers.

Note

The two white plastic caps are the securing nuts for two capacitors located on the inside of the Transceiver Unit rear panel.

All connectors are marked with labels as indicated on the previous drawing.

Compact PC (Operator Station) connectors

The portable computer has rear-mounted connectors and external mounted connectors.

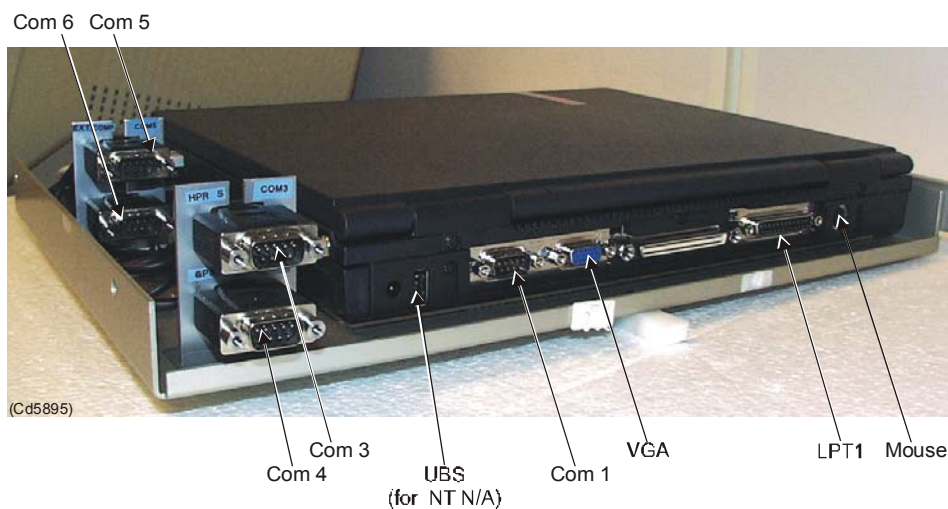

Figure 9 Portable computer's rear side

These connectors are as follows:

- 230 Vac Mains supply.
- 9-pin D-connector for Com1.
 - Connects to HPR 400 Transceiver Unit.
- 25-pin D-connector for LPT1.
 - Connects to optional printer.
- 154-pin D-connector for external VGA monitor.
- 9-pin D-connectors for Com 3-6.
 - Standard RS-232 serial line, connects to external computer or DGPS/depth sensor.
 - Optional RS-232 serial line.

Note

Different portable computers may be used on the HPR 400P system. The physical location of the connectors shown above may therefore differ from type to type.

Standard cables

The following cables are regarded as *standard*, and are connected into the appropriate sockets on the rear of the Compact computer:

C 230 Vac to the Compact PC

Different connector types are used on the various cables to ensure the correct connections.

The following cables are included with the Portable unit.

H 230 Vac to the Transceiver Unit

K Transducer cable

Serial line cables

Standard configuration

The standard configuration is a 4 ports PCMCIA board can be supplied, giving a total of 5 serial ports. (Com 1 on the Compact PC, and Com3-6 on the PCMCIA board.)

Cable A

Note

RS-232 is the standard.

The connections used are recorded in the system software.

Transceiver unit - responder cables J

The Responder function requires an optional responder PCB.

One separate cable is required for each responder to be connected to the transceiver. The transceiver end connects to one of the 4-pin amphenol connectors on the rear of the transceiver unit.

Note

Links LK1 and LK2 located on the rear of the transceiver unit must be in place to power the Responder Controller Board (RPC) with +48 Vdc. This voltage is converted to +24 Vdc on the RPC board to supply the 24 V responder trigger pulse.

It is this +24 V that is available at pin 3 on the Responder 4-pin special connector. This power can be, but is normally not used to supply the responder with power.

Normally the responder is supplied from an external source, either a separate power supply unit or the ROV etc.

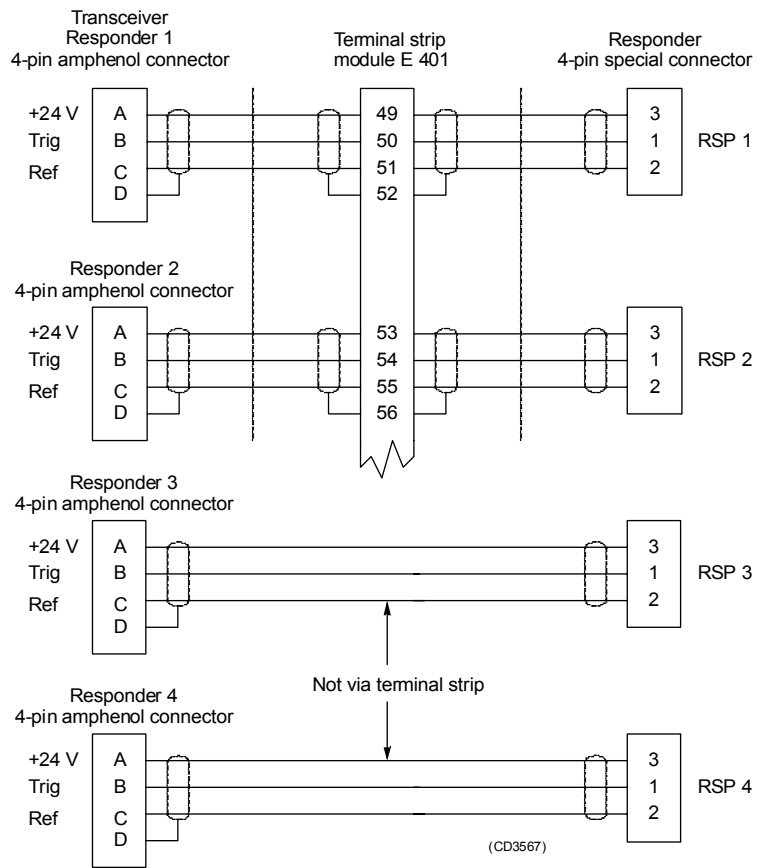

Figure 10 Responder connections

Transceiver Unit pin allocations

Introduction

The connectors on the rear of the HPR 400 Transceiver Unit have the pin allocations as follows (as seen from outside, looking at the rear of the unit).

The connectors not listed here are not used with the HPR 400P Series.

Serial 1

The “Serial 1” socket is a 9-pin delta connector. It is located on the rear panel of the HPR 400 Transceiver Unit, and is identified with the label “SERIAL 1”.

It is used for communication with the computer. The inputs and outputs are optically isolated.

It is used for communication with the APC 10 C computer. The inputs and outputs are optically isolated.

The pins are allocated as follows:

1	422+ input
2	232 input
3	232 output
4	422- input
5	Ground
6	422- output
9	422+ output

Pins 7 and 8 are not used.

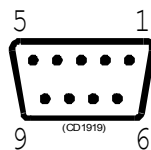

Figure 11 9-pin Delta connector, seen from the outside, looking at the rear of the unit

Serial 2

Not in use.

Serial 3

The “Serial 3” socket is a 9-pin delta connector. It is located on the rear panel of the HPR 400 Transceiver Unit, and is identified with the label “SERIAL 3”.

This serial line is used to connect a serial line gyro or Vertical Reference Unit.

The pins are allocated as follows:

- 1 422+ input
- 4 422- input
- 5 Ground
- 6 422- output
- 9 422+ output

The remaining pins are not used.

→ *Refer to figure 11.*

Serial 4

The “Serial 4” socket is a 9-pin delta connector. It is located on the rear panel of the HPR 400 Transceiver Unit, and is identified with the label “SERIAL 4”.

The serial line is used for synchronization.

The pins are allocated as follows:

- 1/4 Sync 1 in
- 7/8 Sync 2 in
- 9/6 Sync 1 out
- 3/2 Sync 2 out
- 5 Ground

→ *Refer to figure 11.*

Serial 5

Not in use.

Serial 6

Not in use.

Parallel

Not in use.

Analogue I/O

The “Analogue” socket is a 25-pin delta connector. It is located on the rear panel of the HPR 400 Transceiver Unit, and is identified with the label “ANALOG IO/”. The pins are allocated as follows:

- 10** Analogue ground
- 11** Roll
- 12** Pitch
- 22** +15 Vdc
- 23** -15 Vdc
- 24** Common

The remaining pins are not used.

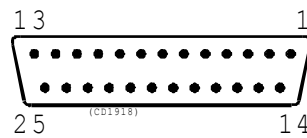

Figure 12 25-pin Delta connector, seen from the outside, looking at the rear of the unit

Gyro/synchro

The “Gyro / synchro” socket is a 15-pin delta connector. It is located on the rear panel of the HPR 400 Transceiver Unit, and identified with the label “GYRO”. The pins are allocated as follows:

- 1** S₁
- 2** S₂
- 3** S₃
- 9** R_H
- 10** R_L

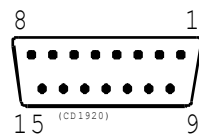

Figure 13 15-pin Delta connector, seen from the outside, looking at the rear of the unit

Responder 1 - 4

The Responder 1 to 4 connectors are 4-pin AMP sockets. They are located on the rear panel of the HPR 400 Transceiver Unit, and are identified with the label “TRANSPONDER 1-4”.

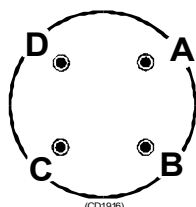

Figure 14 Responder connector, seen from the outside, looking at the rear of the unit

The pins for all four connectors are allocated as follows:

- A + 24 V
- B Trigger
- C Reference
- D Screen

Transducers 1 and 2

These are the transducer connectors for Standard, LF and Narrow beam transducers.

Transducers 3 and 4

The “TRANSDUCER 3” and “TRANSDUCER 4” connectors are 3-pin amp. connectors. The pins are allocated as follows:

- A Signal
- B Ground
- C Signal

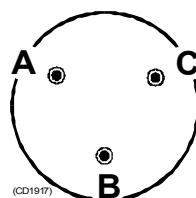

Figure 15 Transducer 3/4 connector, seen from the outside, looking at the rear of the unit

Note

Transducer 2/4 can only be used when 2 Transmit PCBs and 2 Rx PCBs are fitted.

Computer pin allocations

Introduction

The connectors on the rear of the portable computer has the pin allocations as follows (as seen from outside, looking at the rear of the unit).

Com 1, 2 and 3

Com 1, 2 and 3 are 9-pin Delta connectors. The pins are allocated as follows:

1	Carrier detect
2	Receive data
3	Transmit data
4	Data terminal ready
5	Ground
6	Data set ready
7	Ready to send
8	Clear to send
9	Ring indicator

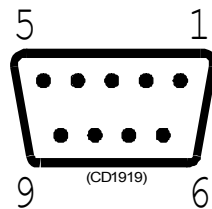

Figure 16 9-pin Delta connector, seen from the outside, looking at the rear of the unit

LPT 1

LPT 1 is a 25-pin Delta connector. The pins are allocated as follows:

1	Strobe (*)
2	Data bit 0
3	Data bit 1
4	Data bit 2
5	Data bit 3
6	Data bit 4
7	Data bit 5
8	Data bit 6
9	Data bit 7
10	Acknowledge (*)

- 11** Busy
- 12** Paper out
- 13** Select
- 14** Auto linefeed (*)
- 15** Error (*)
- 16** Initialize printer (*)
- 17** Select in (*)
- 18-25** Ground

(*) = active low

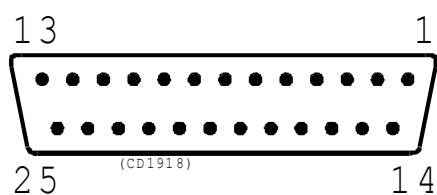

Figure 17 25-pin Delta connector, seen from the outside, looking at the rear of the unit

VGA

VGA is a 15-pin Delta connector. The pins are allocated as follows:

- 1** Red analogue
- 2** Green analogue
- 3** Blue analogue
- 4** Not connected
- 5** Ground
- 6 / 7 / 8** Ground analogue
- 9** Not connected
- 10** Ground
- 11 / 12** Not connected
- 13** Horizontal synchronization
- 14** Vertical synchronization
- 15** Not connected

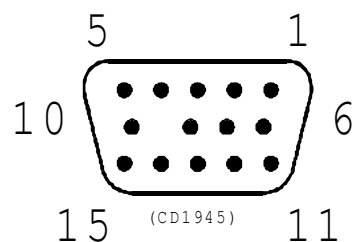

Figure 18 VGA connector, seen from the outside, looking at the rear of the unit

MAINTENANCE

General

The HPR 400P are designed as modular systems. This means that that corrective maintenance is normally performed by replacing modules and circuit boards.

Note

This document may include information regarding equipment not included in your system.

Maintenance philosophy

This technical description is meant to assist the maintenance engineer with intermediate level maintenance operations. This means that the maintenance technician or engineer is expected to replace faulty Line Replaceable Units (LRU) (circuit boards or modules), but not to perform circuit board repairs.

In order to find the faulty component, it is further expected that the maintenance personnel have access to standard electronic instruments, such as oscilloscopes and multimeters.

The personnel designated to perform maintenance on this unit (and the rest of the system) should be well qualified technical personnel, with experience of computer-based electronic circuitry. It is also strongly recommended that the personnel are familiar with the basic principles of hydroacoustic technology, and in particular, positioning systems.

Training courses are available from Kongsberg Simrad AS.

Preventive maintenance

The basic preventative maintenance tasks such as system checks and cleaning, which can be carried out by the operator prior to and on completion of an operation are included.

Transceiver unit

If the transceiver unit is installed within a cabinet, then the fan filter must be checked and vacuum-cleaned every three months or whenever it appears to be necessary. Switch off power before removing the fan covers.

Caution

Maintenance beyond preventive precautions, must be carried out by a qualified service engineer.

Corrective maintenance

Caution

Electronic devices can be destroyed by static electricity. It is essential therefore that full protection against static is practised by service engineers.

Although the unit is resistant to mechanical vibration and shock, every effort must be made to avoid careless handling when the unit is in use or being transported.

A number of error messages are available for use by the system operator. These are not described in this document.

The corrective maintenance on the transceiver unit is limited to operational checks and circuit board replacements. An extension board will be required if the maintenance engineer wishes to perform measurements on the boards during system operation. This is delivered with the standard spare parts kit for the transceiver unit.

→ *For more maintenance information, refer to section HPR 400 Transceiver Unit.*

Tools

No special tools are required.

Transceiver unit

→ *Replacement of transceiver unit parts, refer to page 32.*

Operator station

→ *For information about the Portable PC, refer to separate manual.*

Alarm and event messages

Alarm and events messages are presented in a separate window on the screen, on request. The Alarm and event messages system is described in the APOS On-line help system.

Winch unit

General

- 1 After use, wash the winch unit and cable with fresh water to remove any salt and dirt.

Caution

A high-pressure hose should not be used - the transducer could be damaged.

- 2 Check the transducer. Ensure the face is clean and free from defects.
- 3 Check that the retaining strap is in good condition.
 - This will prevent the transducer falling out of its holder during transportation.
- 4 Check the connector on the “topside end” of the cable. Ensure the rubber seal is fitted and is in good condition.

Cable drum

When the unit is not in use:

- 1 Ensure the protective cap is attached to the drum, and is fitted to the topside connector when the unit is not in use.
 - This will prevent the ingress of water into the connector, and will prevent damage to the connector pins.
- 2 A few drops of oil on the drum and roller bearings, around the winding handle and on the break screw thread will help to prevent corrosion and ensure trouble-free operation when the unit is required.
- 3 Check the lifting strop and look for cuts, frays and other damage.

Transducer

General

Preventive maintenance is limited to keeping the unit clean.

Any marine growth on the transducers will degrade the system's operational capabilities. The transducers should therefore be kept clean.

- The transducers must be handled with care. If the black rubber coating on a transducer is damaged, the transducer will have to be replaced.
- Before any connectors are disconnected, ensure the surrounding areas are dry.
- Inspect the unit for damage at regular intervals. Pay particular attention to the transducer surface. This is manufactured of a synthetic rubber material, and can be damaged easily.

Cleaning the transducers

Note

Use only a stiff, plastic-bristled brush, rounded wooden or plastic scrapers, and fresh water to clean the transducers. Do not use metal tools, solvents, or high-pressure water/steam.

- 1 Using a plastic-bristled brush, cloths and fresh water, remove all traces of salt, debris, mud and weed from the transducer.
- 2 Remove stubborn crustacean growth using a rounded wooden or plastic scraper. Be very careful not to damage the rubber coating on the transducer.

Replacement of the transducer

The transducer is a sealed unit and can not be opened. If the unit is not working, the whole unit must be replaced.

Replacement of transceiver unit parts

Overview

The following circuit boards contained in the transceiver unit are defined as Line Replaceable Units (LRUs):

- Backplane
- Input M - A/B
- A/D Converter (ACM)
- Digital Signal Processor (DSPM)
- Control Processing Unit (CPUM)
- Input/Output (IOM)
- Responder (RPC)
- Transmitter (TxM - A/B)
- DC Power supply (DC - PWR)
- AC Power supply (AC - PWR)

The removal and replacement of these parts is described in the following paragraphs.

→ *Description of each of the boards, see page 42.*

Note

The maintenance engineer must wear a grounding bracelet which is securely connected to the vessel's ground at all times when performing maintenance on the transceiver unit.

Replacement of circuit boards and software

The circuit boards are all plug-in modules and are easy to replace.

- A small screw-driver may be required to open the front panel.
- A special extraction tool (wire hooks) will simplify the removal of a board.
- All the boards and power units are replaced using the same procedure.

Removal of circuit boards

To remove a board is perform the following procedure:

Note

If the transceiver unit is installed in a console or a rack, the operation may be simplified by removing the unit to a work-bench before proceeding with the circuit board replacement.

- 1 Ensure all power to the HPR system, and to other systems connected to the HPR system (e.g. DPS, vertical reference unit etc.) is switched off.
- 2 Remove the system fuses if possible, and label the fuse panel with a tag stating that maintenance is being carried out on the system.
- 3 Use a small screw-driver if necessary, to open the transceiver unit front panel.
 - This is achieved by slackening the two captive screws in the upper corners and hinging the panel downwards. The panel must be allowed to swing below the horizontal if circuit boards are to be removed, so the unit may need to be supported on blocks.
- 4 Locate the desired circuit board and carefully remove any connectors which may be attached to the front of the board.
- 5 Locate the extraction tool hooks into the holes in the upper and lower corners of the board's front edge and carefully pull the circuit board straight out from the transceiver unit rack.

Note

Most of the circuit boards hold software in EPROMS, PROMs and PALs. If a board is to be replaced, the software will have to be moved over to the new board. Also, several links and switches must be set correctly to ensure proper operation. When replacing a circuit board, ensure that the new links and switches match the old.

Software replacement

To replace the software, or moving it to a new board, is a delicate job and must be handled with extreme care. The following precautions must be taken:

- 1 The replacement operation must be performed on a clean and stable workbench or table.
- 2 The table must be covered with an anti-static mat connected to the ship's ground.
- 3 The maintenance engineer MUST wear a grounding bracelet connected to the ship's ground.
- 4 Each software device is identified with a white label. This label holds the following information:
 - Circuit board E.g. DSPM
 - Device number E.g. U15
 - Software version E.g. V1.1
 - Date E.g. 99.09.15
 - Check sum (in hexadecimal) E.g. 05A3

Remove a unit / board

- 1 Identify the unit / board to be removed, and write down the location of pin.1.
- 2 Use a small screwdriver or a special extraction tool, and remove the device carefully from its socket on the source circuit board.
 - Ensure the unit / board is lifted as vertically as possible to prevent damage to the pins.
 - Once removed, handle the unit / board with care.

Insertion

- 1 Identify the socket where the unit / board is to be located.
- 2 Place the unit / board carefully into the socket, and ensure it is orientated correctly.
- 3 Check that all the pins are in the correct holes in the socket, then press the unit / board firmly and evenly into the socket.
- 4 After insertion, check that all the pins are properly inserted into the socket and that no pins are bent.

To remove the backplane

The backplane is located behind the circuit boards, and is accessible through the back of the unit. All the circuit boards and power units must be removed through the front of the unit before the backplane can be removed. All connections to the backplane are made using plugs.

To remove the backplane, follow the procedure below:

Note

If the transceiver unit is installed in a console or a rack, the unit will need to be extracted and taken to a work-bench before proceeding with the backplane removal procedure.

- 1 Ensure all power to the HPR system, and to other systems connected to the HPR system (e.g. DPS, vertical reference unit etc.) is switched off.
- 2 Remove the system fuses if possible, and label the fuse panel with a tag stating that maintenance is being carried out on the system.
- 3 Label all the cables connected into the back of the transceiver unit, and disconnect them.
- 4 Remove all the circuit boards and power units.
 - Ensure the boards are placed in a safe place.

- 5 Use a small screw-driver and remove the 12 screws securing the transceiver unit rear panel in position.
 - The panel is now attached to the unit only by the cables.
- 6 Use a suitable insulated tool or wire link, and discharge the two large capacitors located towards the left side of the rear panel.
- 7 Remove all the connectors attached to the backplane.
 - The backplane should now be readily accessible.
- 8 Slacken and remove the 18 screws securing the backplane into the transceiver unit.
 - The backplane should now be loose, and the engineer can remove it carefully through the back of the unit.

If the backplane is going to be out of the transceiver unit for some time, it is recommended to replace the circuit boards into the front of the unit and close the unit to protect the boards.

Replacement of the backplane

Replacing the backplane is the reverse of removal.

→ *Refer to the procedure on page 34.*

Care should be exercised to ensure that parts fit together correctly before securing screws are tightened. Do not attempt to apply force to any of the parts. Do not over tighten the securing screws.

Replacement of circuit boards

When replacing a board into the rack, care must be exercised to ensure that the board is correctly positioned in the rails before any pressure is applied to the board. If the rear mounted connector pins are damaged, a replacement board will be required.

- 1 Ensure all power to the HPR system, and to other systems connected to the HPR system (e.g. DPS, vertical reference unit etc.) is switched off.
- 2 Remove the system fuses if possible, and label the fuse panel with a tag stating that maintenance is being carried out on the system.
- 3 Locate the correct slot for the board in question.
 - Note that the slots are identified by the board's initials, and the boards are identified by text written onto the component side. In all cases, the board must be located such that the components are to the right of the board.
- 4 Locate the board in the slots and carefully slide the board into the unit. Ensure that the board does not interfere with and cables as it is pushed in. If necessary, hold any cables which may be obstructing the board out from the unit.

- 5 When the connectors on the back of the board begin to mate with the connectors on the back plane, (approximately 5 mm before the board is fully home) check that the board is correctly located then apply even pressure over the front of the board and push it firmly home.
- 6 When the front of the board is fully home, the black plastic board retention clip will latch over the upper edge of the board to keep it in position.
- 7 Carefully replace the front connector (if applicable), ensuring it is pressed fully into the socket.
- 8 Once all the boards are in position, close the front of the transceiver unit.
 - Ensure that the power cable towards the right side of the unit is not crimped as the panel is closed.
- 9 Secure the panel closed using the two screws in the upper corners.

Fuses

Location

The transceiver unit has two mains input fuses. These are located in fuse holders located towards the left side of the rear panel (when seen from the rear).

Four fuses are located on the Responder board (though as this board is optional it may not be included in the transceiver unit) and the AC power supply holds one.

The fuses are as follows:

- **On the rear panel**
 - For 115/230 Vac supply - 5 mm x 30 mm, 2 A, slow-blow.
 - For 115/230 Vac supply - 5 mm x 30 mm, 2 A, slow-blow.
- **On the Responder board**

Four fuse holders are mounted on the board. The fuses to be used are

 - 5 mm x 20 mm, 0.1 A, 24 Vdc, slow-blow.
- **In the AC power supply**

The fuse is contained in a holder located on the rear of the unit. The fuse to be used is:

 - 5 mm x 20 mm, 250 V, 2.5 A, slow-blow.

Caution

Never attempt to use any other size of fuses than those stated.

Replacement

- 1 Switch off the entire HPR system, including other external units which are connected to the HPR system.
- 2 If the suspect fuse is located on a circuit board, remove the board from the transceiver unit following the procedure described in paragraph 35. Replace the blown fuse(s) with the correct size and type of fuse.

Caution

NEVER attempt to use anything except the correct size and type of fuse in the fuse holders. Irreparable damage may be caused to the transceiver unit if the wrong fuses (or anything else) are used.

- 3 Switch on the HPR system power.
- 4 Switch on the other external units.

Caution

If, when a fuse is replaced, it blows again when power is switched on to the system, a more serious fault exists. Do not replace the fuses a second time till the fault has been located and corrected.

HPR 400 TRANSCIVER UNIT

Design

The transceiver unit is constructed of aluminium panels and extruded strip. One of several different cover panel designs may be used depending on the type of installation (console, desk-top, rack, or portable). The dismantling procedures described in this manual refer to the unit as used in the console or 19" rack.

The majority of the circuit boards contained in the unit are standard single-Europe cards, accessible by opening the front of the unit.

Holes (3 mm) are drilled in the upper and lower front corners of each board. These are to attach the wire handle used to extract the board from the unit.

External connections

All external connections to the transceiver unit are made via plugs located on the rear of the unit.

Power supply

The transceiver unit can be powered from a 115 Vac or a 230 Vac supply. Links must be set inside the unit to adapt the unit to the voltage supply. A mains power switch is located on the front panel, together with a *Power on* indicator lamp.

Maintenance

→ *Refer to page 27.*

Theory of operation

Introduction

The HPR 400 Transceiver Unit is the central part of the HPR system. It contains the following:

- Electronic circuitry for transmission of acoustic pulses
- Amplifiers and filters for reception of acoustic signals
- Interfaces to external sensors
- Serial line for communication with the Beam Control Unit (for tracking systems)
- Serial line for communication with the System Controller (an Ethernet link will be available shortly).

The Transceiver Unit's main navigation function is to interrogate transponders and measure the range and bearing to them. The main telemetry function is to transmit and receive acoustic signals.

→ *The operating modes are described on page 7.*

Navigation

The operator selects the active mode of operation. The system can then switch automatically between the selected mode and the other available mode(s). This means that the system can make use of several different types of transponder in the same operation.

Telemetry

The operator may select this mode to send and receive telemetry messages, for example to read the battery status of a transponder. When the transceiver reads the telemetry message from the System Controller, it will convert the message into acoustic signals. This acoustic message contains bursts and pulses with different frequencies and fixed intervals. The transceiver transmits the message(s), and will await the telemetry reply.

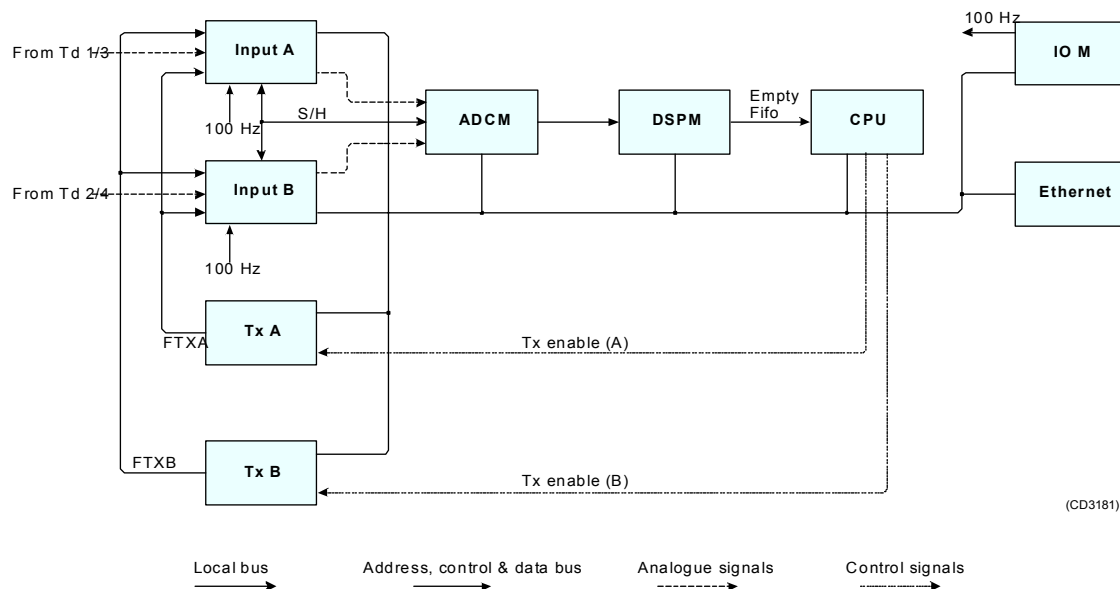

Figure 19 HPR 400 Transceiver unit - functional block diagram

Circuit board identification and main functions

- **Central Processing Unit (CPUEX)**
 - Position calculation
 - Loads and controls the DSPM 50 program
 - Serial line to CDU
 - Controls Tx/Rx hardware
- **Digital Signal Processor (DSPM 50)**
 - Reads data from ADCM
 - Performs pulse detection
 - Performs digital filtering (Fast Fourier Transformations)
- **Analog Digital Converter (ADCM)**
 - Samples the data from INPUTM
 - Converts to binary format
- **Input (INPUTM)**
 - 8-channel receiver
 - Amplifies
 - Bandpass filtering
 - Sample/hold circuitry
- **Transmitter (TXM)**
 - Transmitter
 - Frequency generator for Rx and Tx frequency

- **Input & Output (IOM)**
 - Interface to vertical reference unit (analogue)
 - Interface to gyro (synchro and serial line)
 - TVG initialization
 - Clock for phase locked loop on INPUTM
- **Ethernet (ENET-M)**
 - Ethernet interface
- **Motherboard**
 - Connects all the individual circuit boards together

Internal layout

This section provides a short description of each of the circuit boards contained within the HPR 400 Transceiver Unit.

The transceiver unit holds the following circuit boards and power units:

From left to right:

- A/D Converter (ADCM).
- Digital Signal Processor (DSPM).
- Control Processing Unit (CPUM).
- Input/Output (IOM).
- Transmitter (TXM - A/B).
- DC Power supply (DC - PWR).
- AC Power supply (AC - PWR).

The backplane is located behind the circuit boards, and is accessible through the rear of the transceiver unit. All the circuit boards and power units must be removed through the front of the unit before the backplane can be removed. All connections to the backplane are made using plugs.

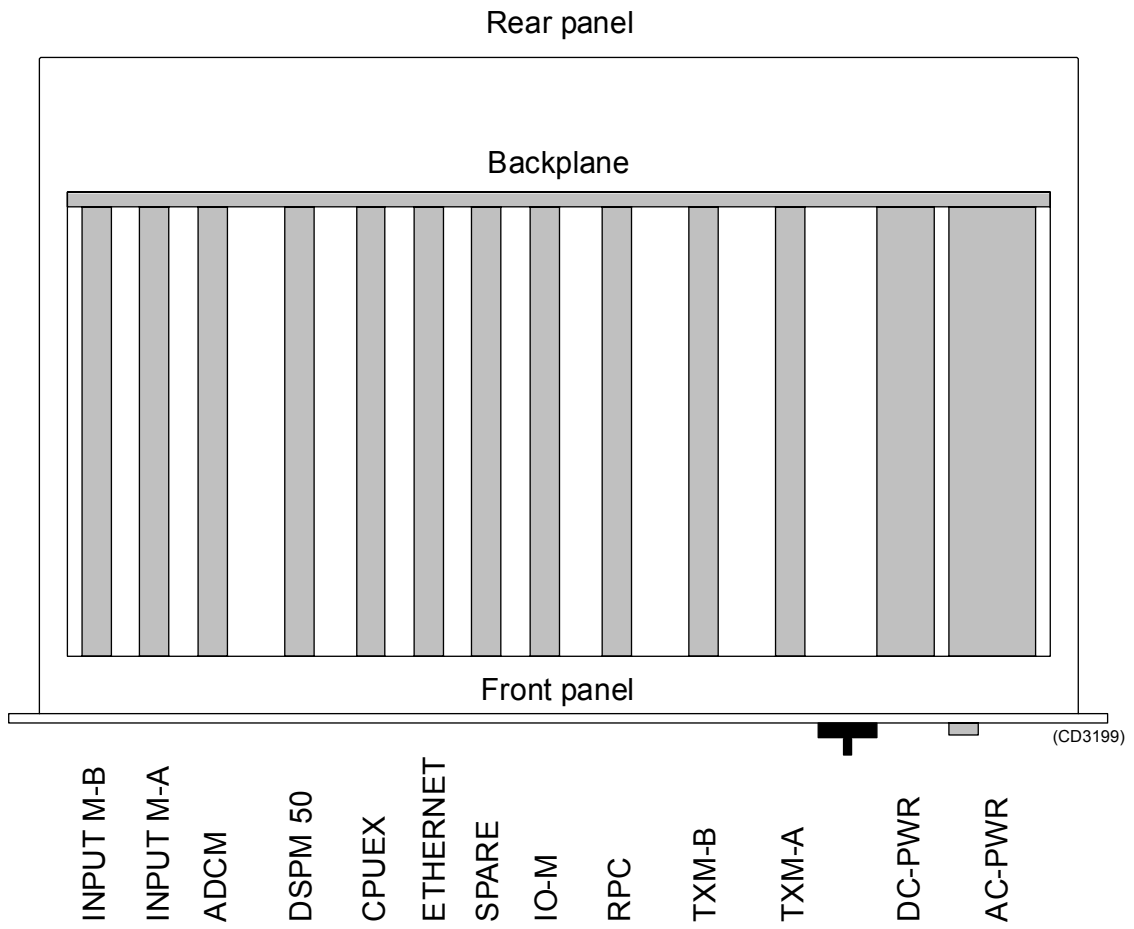

Figure 20 HPR 400 Transceiver Unit - internal layout

Backplane

Location and purpose

The backplane is located in the back of the transceiver unit. This is the interconnection circuit board. It carries connectors and wiring tracks to interconnect the other circuit boards in the transceiver unit. All the other circuit boards plug into the backplane.

Socket mounted components

The board holds only one socket-mounted component:

- U02PAL 20V8 Address decoder. (For TX-PCBs only)

Connections

There are 37 connectors on the circuit board, mounted on both sides. Connectors J1 to J12 are 96-pin Europa connectors for the single Euro-card circuit boards in the unit. For the pin configurations:

HPR 400 Backplane 824-108544 (SH-067)

J1	Input-B
J2	Input-A
J3	ADCM
J4	DSPM
J5	CPUM
J6	Ethernet
J7	Spare
J8	IO-M
J9	RPC
J10	TXM-B
J11	TXM-A
J12	POWERM
P14	8-pin Phoenix plug, male
P15	50-pin 3M, male, flat ribbon cable connector
P16	18-pin Molex, male
P17	8-pin Phoenix plug, male
P18	2-pin Phoenix plug, male
P19	2-pin Phoenix plug, male
P20	2-pin Phoenix plug, male
P21	34-pin 3M, male, flat ribbon cable connector
P22	50-pin 3M, male, flat ribbon cable connector

P23	50-pin 3M, male, flat ribbon cable connector
P24	2-pin Phoenix plug, male
P25	2-pin Phoenix plug, male
P26	9-pin Molex, male
P27	3-pin Molex, male
P28	9-pin Molex, male
P29	3-pin Molex, male
P30	6-pin Molex, male
P31	9-pin Molex, male
P32	3-pin Molex, male
P33	9-pin Molex, male
P34	3-pin Molex, male
P35	6-pin Molex, male
P36	3-pin Molex, male
P37	3-pin Molex, male
P38	3-pin Molex, male

Links

LK 1	0 V for responder power. Link IN means internal power
LK 2	+48 V for responder power. Link IN means internal power
ST 1	Link 1-2 for VC_B to Input-A P1 c7
ST 1	Link 2-3 for VC_A to Input-A P1 c7 (Normally closed) Seen from rear: ._. .
ST 2	Link 1-2 for VC_D to Input-B P1 c7
ST 2	Link 2-3 for VC_C to Input-B P1 c7 (Normally closed) Seen from rear: ._. .
ST 7	EXRDY- Normally out
ST24	VC_B, (TVG), TD1. Normally in
ST25	VC_D, (TVG), TD2. Normally in
ST26	Link 1-2 for VEE(-5 V) to Input A/B P1 abc 28
ST26	Link 2-3 for VCC(+5 V) to Input-A/B P1 abc 28 (Normally closed) Seen from rear: ._. .

InputM

Purpose

The HPR 400 Transceiver Unit holds two InputM boards, B and A. The purpose of the InputM circuit board is to amplify transducer signals, perform demodulation and narrow band filtering, and present the output signals via Sample and hold circuitry.

The InputM board is a single Euro-card circuit board.

The InputM circuit board is designed for eight individual channels, using identical analogue channel hybrid circuits. However, only five are fitted. The first four (grouped) are used for the SSBL system, the fifth (set apart from the others) is for the LBL system. The board is also equipped with digital circuitry common to all the analogue channels.

Connections

The InputM circuit board carries one connector. This is a 96-pin Europe connector mounted on the rear edge of the board, used to link the board into the backplane.

Test points

TP 1	Transducer signal channel 1
TP 2	Transducer signal channel 2
TP 3	Transducer signal channel 3
TP 4	Transducer signal channel 4
TP 5	Not fitted
TP 6	Not fitted
TP 7	Not fitted
TP 8	Not fitted

- The demodulator frequency should be present at “Demfil” pins 1 and 2. The frequency should be two times the actual listening frequency. Note that the frequency will shift by the transmitter pulse after the reply is received. (50 Hz off).
- The bandwidth clock should be present on “Demfil” pin 14, and should be 50 times the actual bandwidth.
- The Sample/Hold clock should be present on U13 pin 13, and then go to pin 15 on all the “Demfil” packages.

The signal reply pulses (5 to 7 Vp-p) should be present on the test points in front of the “Demfils”. (TPs 1, 2, 3, 4 and 8).

- The signal pulse envelope should be present on “Demfil” pins 27 and 28. Maximum amplitude should be 4 V p-p.

- LK1

Link 1-2	Not used
Link 2-3	2 x mod. freq. telemetry normally closed

- LK2

Link 1-2	Not used
Link 2-3	Not used

- LK3

Link 1-2	Not used
Link 2-3	Not used

- LK4 / LK5

Link 1-2	LK 4 pin 2 is linked to LK 5 pin 2 to set bandwidth for wide and telemetry
----------	--

Analogue digital converter (ADCM)

Purpose

The purpose of the ADCM is to perform analogue to digital conversion. It offers conversion of 32 analogue input channels and temporary storage of data in dual port RAM. Up to eight conversion sequences can be programmed into an EPROM. Data sets are stored alternately in two banks of RAM.

Board description

The ADCM is designed to the single Euro-card circuit board standard, with four layers. Two layers are used for the signals, two layers are used for the power supply. The board is equipped with two connectors, one located at each end. A 50-pin connector (P2) is the only front mounted device visible when the board is in position in the HPR 400 Transceiver Unit.

The ADCM circuit board provides 32 multiplexed analogue input channels. Dual 16-bit multiplexers are used to select analogue input signals obtained from the sample-and-hold outputs of the Input-M circuit board. Each output from the Input-M provides a real and imaginary analogue signal between ± 2.5 Vdc.

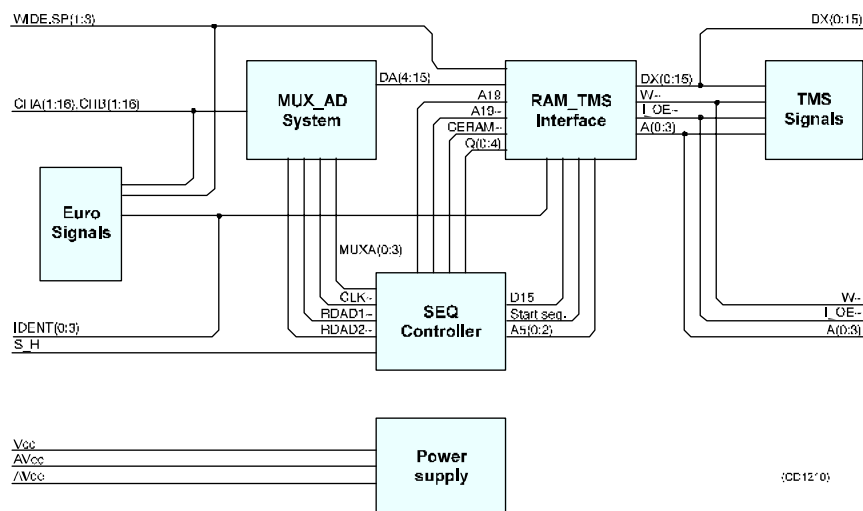

Figure 21 A / D Converter (ADCM) - block diagram

The control lines IDENT (0:3) (ref block diagram) provide the board with a unique identification code which is set by jumpers S1 - S4. The external address lines A (0:3) must match this code to select the board.

Connections

The board carries two connectors, one located at each end of the board. **P1** is a 96-pin, male, right-angled connector. It connects the ADCM into the motherboard. **P2** is a 50-pin, male, right-angled connector with ejector/latch. It is located on the front edge of the board.

TP 1	ADC, IC4 input (real signal)
TP 2	ADC, IC4 BUSY~
TP 3	ADC, IC8 input (imaginary signal)
TP 4	ADC, IC8 BUSY~
TP 5	START_SEQ
TP 6	CLK~
TP 7	IC21 CK (multiplexer address latch)
TP 8	S_H
TP 9	+5 Vdc digital
TP 10	DGND
TP 11	+12 Vdc analogue
TP 12	Analogue ground
TP 13	-12 Vdc analogue

Digital signal processor (DSPM 50)

Location and purpose

The Digital Signal Processor (DSPM 50) board is located fourth from the left in the HPR 400 Transceiver Unit rack. It is designed as a general purpose single board computer, and its main task is to perform digital signal processing.

Board description

The DSPM 50 is a single Euro-card circuit board, constructed of eight layers. It holds two LEDs and one 50-pin connector, P2, on its front edge.

The DSPM 50 is a general purpose digital signal processor board. It utilizes the TMS 320C50 Digital Signal Processor manufactured by Texas Instruments. The DSPM 50 operates on a 50 MHz clock frequency, and holds a total of 128 Kb memory for program and data storage. The program memory is loaded from a main control processor unit (the Central Processing Unit (CPUEx)) through a general bus interface in the 96-pin Europa connector P1.

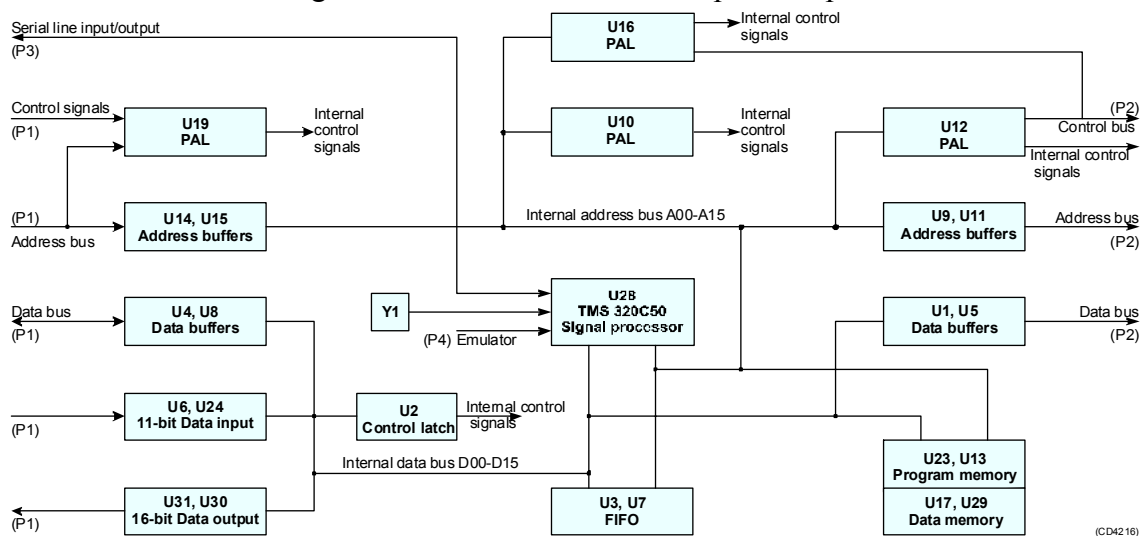

Figure 22 Digital Signal Processor (DSPM 50) - block diagram

The board requires +5 Vdc, and consumes approximately 250 mA.

Connections

The MUNAV Digital Signal Processor (DSPM 50) holds two connectors (with place for two more which are not used in the HPR 400 system):

P1	96-pin, male, right-angled Europa connector placed at the back edge of the circuit board
P2	50-pin, male, low-profile flat ribbon cable connector placed at the front edge of the circuit board
P3	Serial line connector - not used
P4	Emulator connector - not used

Test points

TP1	FIFO Empty flag
-----	-----------------

The user may check basic functions by using an oscilloscope and measure on the following points:

- The HOLD/ signal on U2 pin-2 and RS/ on U2 pin-5. These must both be low when loading the program memory.
- The signal STRB/ on U16 pin-4. A pulse train will be observed when the signal processor is running.

Links

Lk 1	Normally on - enables D1
Lk 2	Normally on - connects HOLD/ to TMS320C50
Lk 3	Normally on - enables D2
Lk 4	Normally on - connects RS/ from U2
Lk 5	Normally open - selects clock option
Lk 6	Normally open - selects clock option
Lk 7	Used for test, Normally on - connects clock to TMS320C50
Lk 8	Normally open - selects MP or MC mode of TMS320C50
Lk 9	GND
Lk 10	+5 V
Lk 11	Normally A. A selects A14, B selects A15 to program ram P3

LEDs

LED D1	On when FIFO is empty
LED D2	On when board is running

Transmitter (TXM)

Purpose

Two Transmitter (TXM) boards are used in the HPR 400 Transceiver Unit. These are TXM-A and TXM-B. The Transmitter board (TXM) is a general purpose transmitter.

Board description

The TXM is designed to the single Euro-card standard, and comprises four layers, and contains its own frequency generator, power control and power supply circuits (the board feeds both the Rx and CPU circuit boards when in the Mutran mode).

The two boards used in the system are identical in all respects.

The transmitter board holds two MAX663 voltage regulators which provide the voltages used in the transmitter. It also has a crystal oscillator which is used as the Tx frequency source and a direct numerical synthesizer for generating the correct Tx frequency.

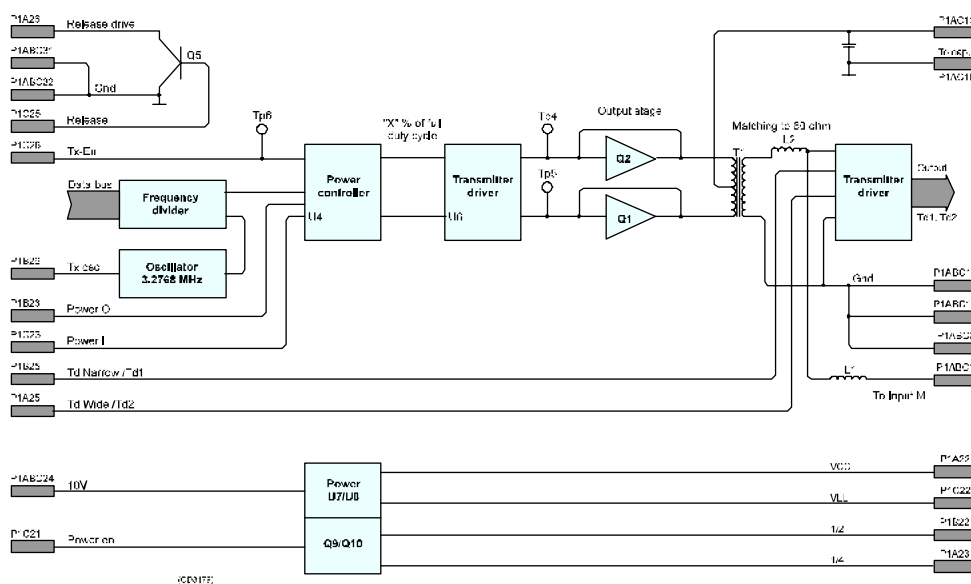

Figure 23 Transmitter circuit board - block diagram

Front mounted devices

The TXM board holds two test points and two factory-set links on its front edge.

Socket-mounted components

U5 (PAL)	Programmable I/O controller
----------	-----------------------------

Connections

The board has one 96-pin, male, right-angled connector (P1) located on the rear edge of the board to link the board into the backplane.

Test points

The following oscilloscope test points are available to assist the maintenance engineer:

TP1	FTx, 50% duty cycle
TP2	Transmitter pulse, 10 ms, voltage depending on power
TP3	+10 V when POWERON is ON, (Mutran). +15 V for Munav
TP4	10 ms burst to Tx driver, duty cycle dep. on power control. +5 V when POWERON is ON
TP5	180 out of phase with TP4"
TP6	+5 V, 10 ms pulse from CPUM
TP7	GND

Links

The TXM board holds the following links:

LK1	Link 1-2 if U5(Pal) is in use. Normally closed Link 2-3 for external frequency burst
LK2	Link 1-2 if U5(Pal) is in use. Normally closed Link 2-3 for external frequency burst

Switches

The TXM board holds no switches.

“Powerbox” AC power supply

This power supply is a sealed unit. In the event of malfunction, replace the unit.

Purpose

The **POWERBOX ESA-K105U/XS** AC power supply enables the HPR 400 system to be powered from a 230 Vac supply.

The **POWERBOX ESA-K104U/SS** AC power supply enables the HPR 400 system to be powered from a 230 Vac or 115 Vac supply.

Board description

The unit is purchased from an external supplier. It is based on a commercially available power supply, though has been altered to Simrad’s specifications. The unit is open to allow cooling air around the components, but is designated “Repair by replacement”. It is designed to be installed in a standard 19 rack.

Technical specifications

The unit physical specifications:

Width	12 TE
Height	111 mm
Length	168.5 mm
Weight	700 g
Operating temperature	0°C to 80°C
Storage temperature	-25°C to +85°C
Efficiency	80% typical
Isolation and safety	To EN 60 950
EMI/RFI standards	To EN 55 022B (VDE 0871 B)

Electrical characteristics

Note

Switching between 115 Vac and 230 Vac is performed using straps inside the unit.

Socket-mounted components

None - this power supply is a sealed unit and must not be “adjusted” by the system maintainer.

Connections

The power supply unit is plugged into the backplane by a connector comprising fifteen 5 mm spade terminals. The terminals are allocated as follows:

P1 pin allocation 15-pin connection block	
Pin	Signal description
4	+ Vo1
6	+ Vo1
8	+ Vo1
10	+ S
12	- S
14	- Vo1
16	- Vo1
18	- Vo1
20	
22	
24	
26	
28	230 Vac in (L)
30	230 Vac in (N)
32	GND

LEDs

The front of the unit holds 1 green LED which indicates the existence of the 48 Vdc output.

Fuses

The unit holds an input fuse, located in the rear of the unit. The fuse is:

- 5 mm x 20 mm, 250 V, 2.5 A, slow-blow

Caution

Nothing else must be used.

Control Processor Unit (CPUEx)

Purpose

The CPUEx is a single-board computer utilizing the 80386EX microprocessor. The purpose of the board is to control the operation of the transceiver unit.

Board description

The CPUEx is a standard eight-layer single-Europe board. One edge connector connects to the motherboard. The front edge holds a 34-pin connector, four LEDs, two test points and link Lk7.

The CPUEx is designed as a Control Processor Unit using the 80386EX microprocessor from Intel. The board has sockets for an 80387SL numeric processor and flash memory. The board also holds RAM memory for program and data storage, serial lines, interrupt inputs, general I/O lines and a general bus interface (96-pin Europa connector).

The board contains 6 TTL inputs (ID1 to ID6), 12 TTL outputs (ID9 to ID16 and OUT1 to OUT4), nine external interrupt inputs and six 16-bit timers.

Two separate serial lines with separate programmable baud-rate control are available. Selection between RS-232 and RS-422 is made by links on the inputs. Both serial lines supply RS-232 and RS-422 as outputs at the same time.

Connections

There are two connectors; one placed at each end of the circuit board.

P1	96-pin, male, right-angled Europa connector
P2	34-pin, male, flat ribbon cable connector

Test points

TP 1	GND
TP 2	+5 V

Links

LK 01	Link 1-2 for RS 422 input serial line A Link 2-3 for RS 232 input serial line A
LK 02	Link 1-2 for RS 422 input serial line B Link 2-3 for RS 232 input serial line B
LK 03	Normally closed, software control

LK 04	Ram dependent
LK 05	On = enables D1 - D4
LK 06	On = WD enable
LK 07	Reset connector

LEDs

D1 -D4	Software-controlled, front mounted
--------	------------------------------------

Oscilloscope check points

The maintenance engineer can check the basic functions by using an oscilloscope and measuring on the following points:

- The signal ADS/ on U16 Pin 3, observe the pulses when the board is (should be) running. Check for one positive pulse to start every instruction cycle.

Input/output board (IO/M)

Purpose

The Input/Output board (IO/M) is designed to the single Euro-card circuit board standard. It is designed to interface the most common SSBL and LBL inputs and outputs, such as a vertical reference unit, course gyro, external synchronization and serial lines.

Board description

The vertical reference unit, gyro and serial line 1 (to the system controller) are galvanically isolated. Serial lines 2 and 3 are dedicated to tracking interface. These serial lines are galvanically isolated on the Serial Interface board, SIF.

Serial line 1 is available with a programmable baud-rate control, coming from the CPU board. Selection between RS-232 and RS-422 is made using links on the inputs. The serial line may also be inverted by links on the board. The serial line may supply RS-232 and RS-422 as outputs simultaneously.

Serial lines 2 and 3 are RS 422 only, controlled by U3, 82530.

U13 is the address buffer for the system bus. It contains two address bits. The bus is available on P1. U5 and U6 are the bidirectional data transceivers. The data bus is also available on P1.

The 82530 (U3) Serial Communication Controller contains two serial lines identified as 2 and 3".

Four analogue inputs are supported, made switchable by means of the U10 multiplexer. Two of the inputs are dedicated for Roll and Pitch inputs from an external vertical reference unit (VRU).

Four analogue outputs are provided. These are originally designated as TVG outputs (Time Varied Gain) to preamplifier boards and/or transducers. The analogue outputs are generated by the D/A converter U20.

One synchro input intended for a course gyro input, and two differential inputs, are provided.

Front mounted devices

A 50-pin connector, P2, is the only device mounted on the front edge of the board.

Connections

There are two connectors; one at each end of the circuit board.

P1	96-pin, male, right-angled connector
P2	50-pin, male, flat ribbon cable connector

Test points

TP 01	GND
TP 02	Analogue inputs, between multiplexer and AD
TP 03	Pitch
TP 04	Roll
TP 05	VCC
TP 06	VCC1
TP 07	GND1
TP 08	Pitch input
TP 09	VRU common
TP 10	Roll input

LK 01	Link 1-2 for direct Analog_1 input Link 2-3 for Analog_1 input via amplifier.
LK 02	Link 1-2 for direct Analog_2 input Link 2-3 for Analog_2 input via amplifier.
LK 03	Link between analogue and digital ground Normally closed.
LK 04	Digital ground to D/A converter. Normally closed.
LK 05	-5 Vdc to D/A converter.
LK 06	A/D converter 20 V input. Normally closed.
LK 07	A/D converter 10 V input.
LK 08	Link 1-2 for inverted Serial line 1, Tx. Link 2-3 for non-inverted Serial line 1, Tx. Normally closed.
LK 09	Link 1-2 for inverted Serial line 1, Rx. Link 2-3 for non-inverted Serial line 1, Rx. Normally closed.
LK 10	Link 1-2 for RS422 input serial line 1 Normally closed. Link 2-3 for RS232 input serial line 1.
LK 11	Analogue ground to D/A converter.
LK 12	200 Hz reference frequency.
LK 13	100 Hz reference frequency. Normally closed.

R 13	Adjustment of bipolar offset, A/D converter.
R 14	Adjustment of reference voltage A/D converter.

The IO/M board holds no switches.

Responder controller (RPC) board (option)

Purpose

The purpose of the responder controller (RPC) board is to provide responder trigger pulses as requested from the Operator Station.

Board description

The RPC board is located behind the main control panel. It is designed to the single Euro-card standard. The board holds four identical opto-isolated responder trigger circuits, and communicates with the TMC board in the PC via a flat cable.

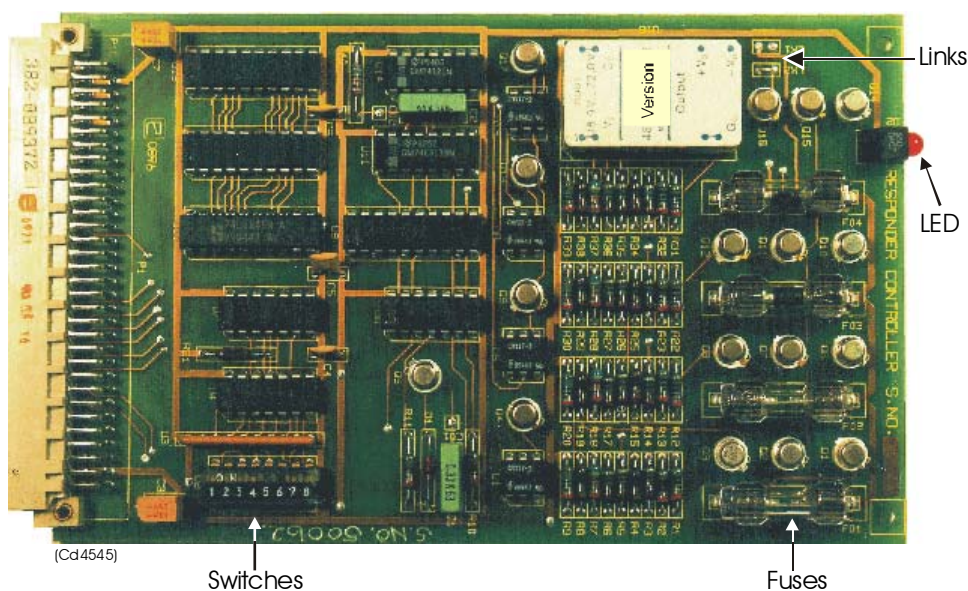

Figure 24 RPC board

The RPC board's address is set by means of the DIL switch U2.

Switches

Dil switch U2	Address switch block
---------------	----------------------

- Switches 5 and 6 must be set to **OFF**.
- All other switches in the block must be set to **ON**.

Front mounted devices

The RPC board carries four fuses and a diode mounted on its front edge.

Socket-mounted components

The board carries no socket-mounted components.

Connections

The board holds one connector, P1, located on the back edge of the board. This connects the board into the transceiver unit backplane.

P1	64-pin, male, right-angled connector
----	--------------------------------------

Test points

The RPC has no specific test points for use by the maintenance engineer.

Links

LK1	Connected only when 24 V is supplied and U16 is not mounted
LK2	Always connected

LED

D2	Lights when board is transmitting
----	-----------------------------------

Fuses

The board carries four 0.1 A, slow-blow fuses, on the +24 Vdc lines.

DC power supply (DC - PWR)

The DC-PWR is located second from the right in the rack. The board is designed by Simrad, though the power converter units mounted on the board are bought from an external source.

Purpose

The purpose of the MUNAV Power Supply (POWERM) is to supply the electronic circuitry with low level DC voltages. The unit can provide several different voltages, in this system 15 Vdc is used.

Board description

This DC supply is based on EriPower DC-DC converters, which produce the following voltages:

- +5 Vdc
- +15 Vdc
- -15 Vdc

The ± 15 Vdc is converted to ± 5 Vdc by means of serial regulators.

When a TTL level signal is applied to either POWER-ON or POWER-UP, the gate on Q1 will be forced to a low level by Q2. This will set the Q2 to a ON condition, and thus pass this power, supplied to input DC-IN1 or DC-IN2.

Note

There is a start-up delay of approximately 40 ms between the arrival of a Power On pulse and a settled +5 Vdc output.

The constant current block is based on a three-terminal voltage regulator (U1) LM317HVK and a serial resistor (R1). The output current will increase until the voltage across R1 is equal to V_{REF} . (1.2 Vdc). A 1 Ω resistor gives a current of approximately 1.2 A. The DC-DC converter used is a 25W EriPower PKA4000 series, requiring an input voltage between 39 Vdc and 64 Vdc.

The output data is as follows:

+5 Vdc output:

Nominal load	3.1 A
Maximum load	5 A

± 15 Vdc output:

Nominal load	0.31 A
Maximum load	0.8 A

WARNING

The total load must never exceed 25 W for each EriPower unit, i.e. 50 W in total.

To generate the ± 5 Vdc analogue voltage (AVCC/AVEE) the ± 15 Vdc outputs from the DC-DC converter are fed to U2 and U3.

Socket-mounted components

The board holds no socket mounted components.

Connections

The board carries one 96-pin Euro-connector to link it into the Transceiver Unit's backplane.

Test points

TP1	+ 5 V digital
TP2	Digital ground
TP3	+ 48 V analogue input
TP4	Analogue ground input
TP5	Analogue ground output
TP6	- 15 V analogue output
TP7	+ 5 V analogue output
TP8	+ 15 V analogue output

Links

The board has a link field (LKI) comprising four links S1, S2, S3 and S4.

- These links are used to swap polarity on the DC-DC converted input pins.
- A 48 volt supply requires S1 and S3 to be closed.

Switches

The board holds no switches.

TECHNICAL SPECIFICATIONS

SSBL Accuracy

Transducer type	Accuracy	The specification is based on:
HPR 400 PMT 301, 20-32 kHz: - Wide beam $\pm 80^\circ$	$\leq 2\%$ of slant range	<ul style="list-style-type: none"> • Free line of sight from transducer to transponder. • No influence from ray-bending. • Signal-to-Noise ratio in the receiver beam ≥ 20 dB. rel. $1\mu\text{Pa}$. • No error from heading and roll/pitch sensors.
HPR 400 Standard 20-32 kHz: - Wide beam $\pm 80^\circ$ - Medium beam $\pm 55^\circ$	$\leq 5\%$ of slant range $\leq 2\%$ of slant range	
HPR 400 Narrow beam 20-32 kHz: - Wide beam $\pm 80^\circ$ - Narrow beam $\pm 22.5^\circ$	$\leq 5\%$ of slant range $\leq 1\%$ of slant range	
HPR 400, LF 10-15 kHz: Wide beam $\pm 80^\circ$ Medium beam $\pm 55^\circ$	$\leq 5\%$ of slant range $\leq 2\%$ of slant range	

LBL accuracy

Transducer type	Accuracy	* The position accuracy for LBL operation depends on:
Dunking, MF 20-32 kHz: - Narrow beam $\pm 50^\circ$	*	<ul style="list-style-type: none"> • Transponder array geometry • Sound velocity errors • Signal-to-Noise ratio. <p>However, the accuracy can be shown by simulations. Range accuracy's down to a few centimetres can be obtained, while ROV and vessel positions can be calculated to within a few decimetres.</p>
Dunking, MF 20-32 kHz: - Wide beam approx $\pm 50^\circ$	*	
Dunking, LF 10-15 kHz: - Beam approx $\pm 50^\circ$	*	
RTD 333, MF 20-32 kHz: - "Doughnut" shape	*	

The following "one sigma" error contribution to the range measurements are assumed (20-30 kHz system):

- Range reception with 20 dB S/N: 0.15 m
- Range reception in the transponder: 0.15 m
- Range error due to TP movement: 0.10 m
- Range error due to rig movement: 0.20 m

The random errors are added as Gaussian noise to the measurements.

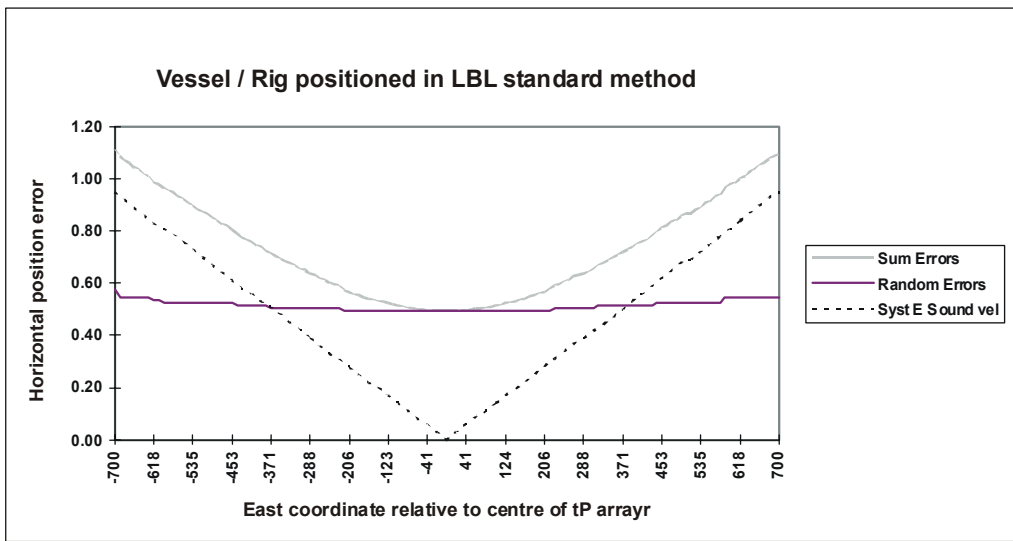

(Cd5534)

Figure 25 Error in the horizontal position

The figure shows the error in the horizontal position when the Rig moves within the transponder array. The simulations are done with the following parameters:

- Four LBL transponders placed on the seabed in a circle with radius 636 m.
- The water depth is 1200 m.

The error is showed as a function of the East coordinate. The north coordinate is retained at zero, and the East coordinate zero is consequently the centre of the array. We have assumed that the wide beam of the transducer is used, and that the S/N when receiving the transponder replies is 20 dB. The effect of a systematic error in the Sound velocity of 1 m/s is also showed. When being in the centre of the array, that error causes no position error. When being in the outer parts of the array, that error causes a significant systematic error in the position.

Range capabilities

The range capabilities depends on:

- Vessels noise level
- Attenuation of the transponder signal level
- Transponder type
- Ray-bending effects may also reduce the operating range.

The figures in the table below are based on 20-32 kHz systems and are approximate values for guidance.

- The HiPAP system will in most cases have longer range capabilities than specified below, due to its narrow receiving beam.

Transponder type/ range capabilities	Operating range	The specification is based on:
Standard transponder / w/ 188 dB rel. 1mPa ref. 1m	Typical 1000 m - 1500 m	<ul style="list-style-type: none"> • Free line of sight from transducer to transponder • No influence from ray-bending. • Signal-to-Noise ratio in the receiver beam ≥ 20 dB. rel. 1μPa. • No error from heading and roll/pitch sensors.
High power transponder / w/ 195 dB rel. 1mPa ref. 1m	Typical 1500 m - 2000 m	
High power transponder / w/ 206 dB rel. 1mPa ref. 1m	Typical 2500 m - 4000 m	

HPR 400 portable unit

The HPR 400 Portable unit is a 19 inch wide and 6U high transport housing. This housing has an internal support frame with anti vibration mounts, where the HPR 400 is mounted.

Dimensions:

Dimension: W x H x D	530 x 360 x 565 mm
Weight	approx 33 kg

Frequencies:

Medium Frequency (MF)	21,000 Hz - 32,500 Hz
Low Frequency (LF)	9,500 Hz - 15,750 Hz
Mains supply	230 Vac (110 Vac on request)

Temperatures:

Operating temperature	-10° to +55°C
Storage temperature	-40° to +70°C

HPR 400 Transceiver Unit

This is a 3U high, 19 inch rack electronic unit for acoustic signal transmitting and receiving processing.

Power supply:

Voltage	185 – 264 Vac
Frequency	50-60 Hz
Consumption max.	55 W

Temperature:

Storage	-20 to +60 °C
Operating	0 to +55 °C

Humidity:

Storage / operating	90% relative 80% relative
---------------------	---------------------------

Weight:

19inch/3u rack module	approx. 9 kg
-----------------------	--------------

Heading reference:

- Synchronous
- Serial RS-422 SKR format
- Serial RS-422 STL format
- Serial RS-422 NMEA format
- Serial RS-422 Seatex MRU or Seapath
- Serial RS -422 DGR format (Tokimec DGR 11)

Roll and pitch reference:

- Analogue Sine $\pm 90^\circ \pm 10V$
- Analogue Sine $\pm 15^\circ \pm 10V$
- Analogue linear $\pm 60^\circ \pm 10V$
- Analogue Seatex MRU $\pm 20^\circ \pm 10V$
- Serial RS-422 Seatex MRU or Seapath

Transducer frequency combinations:

- 2 SSBL MF and 2 LBL/Telemetry MF
- 2 SSBL LF and 2 LBL/Telemetry LF
- 1 SSBL & 1 LBL/Telemetry MF and/or 1 SSBL & 1 LBL/Telemetry LF

Responder drives	max. 4
Transponders in use	max. 56 (HPR 400) + 14 (HPR 300)
Transponder channels	HPR 300 and HPR 400

Compact PC (Operator station)

→ *Refer to separate manual.*

Transducers

General

This section presents the technical specification for the following transducers:

- PMT 301 - Portable Mini Transponder
- Standard MF (wide/medium beam) Transducer
- MF (wide/narrow beam) Transducer
- LF (wide beam) Transducer
- **Dunking transducers:**
 - MF narrow beam
 - MF wide beam
 - LF narrow beam
- RTD 333 - MF ROV Transducer

PMT 301 - Portable Mini Transducer

→ *Outline dimensions, refer to page 82.*

Maximum depth rating	50 m
Housing material	Bronze
Weight in air / water	8.6 kg / 6.1 kg
Transducer-cable	Normally delivered with 30 m Optional, specified length
Connector 19-pin female	SOURIAU
Transmission response	-173 dB rel 1mPa/W rel 1m at 23 kHz

Sensor performance

Total range	$\pm 60^\circ$
Linear range	$\pm 45^\circ$
Threshold	0.001°
linearity:	
- Null to 10°	$\pm 0.1^\circ$
- 10° to 45°	$\pm 1\%$
- 45° to 60°	Monotonic
Null repeatability	0.05°
Cross axis error	0.3 sec
Frequency response (-3dB)	0.5 Hz

RF susceptibility	$< \pm 2^\circ$
Accuracy inclinometer	0.2°

- Transducer and transducer-cable are with Souriau underwater connector.
- Delivered with a handy mounting bracket for easy installation onto a pole.
- Inclinometers incorporated for automatic compensation of Roll and Pitch movements. No vertical alignment necessary from the same inclinometers. Can be tilted up to 20 degrees.

Standard MF (wide/medium beam) transducer

→ *Outline dimensions, refer to page 83.*

Maximum depth rating	50 m
Housing material	Bronze
Weight in air / water	47 kg / 33.2 kg
Transducer cable	Normally delivered with 30 meter Optional, specified length
Connector 19-pin	SOURIAU
Transmission response	180 dB rel 1mPa/W rel 1m at 23 kHz

MF (wide/narrow beam) transducer

→ *Outline dimensions, refer to page 84.*

Maximum depth rating	50 m
Housing material	Bronze
Weight in air / water	63 kg / 44.6 kg
Transducer cable	Normally delivered with 30 meter Optional, specified length
Connector 19-pin	SOURIAU
Transmission response	178 dB rel 1μPa/W rel 1m at 23 kHz

LF (wide beam) transducer

Same as for the MF (wide/narrow beam) transducer described above.

Dunking transducers

MF narrow beam transducer

→ *Outline dimensions, refer to page 85.*

Maximum depth rating	100 m
Housing material	Bronze
Weight in air / water	5 kg / 3 kg
Operating frequency	30 kHz
Beam width	approx. 100° at -6dB
Transmission response	172 dB rel 1 μ Pa/W rel 1m at 23 kHz
Reception response	-190 dB rel 1V/ μ Pa

MF wide beam transducer

→ *Outline dimensions, refer to page 86.*

Maximum depth rating	100 m
Housing material	Bronze
Weight in air / water	3.5 kg / 2.5 kg
Operating frequency	30 kHz
Beam width	approx. 200° at -3dB
Transmission response	172 dB rel 1 μ Pa/W rel 1m at 23 kHz
Reception response	-190 dB rel 1V/ μ Pa

LF transducer

Maximum depth rating	100 m
Housing material	Bronze
Height	355 mm
Diameter (max)	128 mm
Weight in air / water	5 kg / 3.5 kg
Operating frequency	12 kHz
Beamwidth	approx. 100° at -6dB
Transmission response	172 dB rel 1 μ Pa/W rel 1m at 23 kHz
Reception response	-190 dB rel 1V/ μ Pa

RTD 333 - ROV Transducer

→ *Refer to the HPR 400S Instruction manual.*

SPARE PARTS

Overview

This document contains the spare part for the HPR 400 Portable units. All parts may be ordered directly from Kongsberg Simrad AS or our appointed dealer.

Note

The lists contain only those items that are most likely to be required; other items may be available on request. Note also that several items may be purchased locally; these items are marked accordingly in the lists.

HPR 400 Transceiver unit

Extender board	382-057634
Backplane	382-101504
Input MF	382-088903
Input LF	382-089475
A/D converter (ADCM)	382-083755
Digital Signal Processor (DSPM 50)	382-110358
Control Processor Unit (CPU EX)	382-112510
Input/Output (IO-M)	382-088886
Responder Controller (RPC) (Option)	382-089372
Transmitter (TXM) MF	382-088912
Transmitter (TXM) LF	382-089556
DC power supply (DC-PWR)	382-088945
AC power supply (AC-PWR)	382-086646

Fuses

Local supply of fuses is recommended. All fuses are “slow-blow”.

Transceiver unit rear panel	6 mm \varnothing x 30 mm, 3.15 A
Transceiver unit rear panel	6 mm \varnothing x 30 mm, 2 A
Responder PCB	5 mm \varnothing x 20 mm, 0.1 A
AC Power supply	5 mm \varnothing x 20 mm, 2.5 A

Portable PC

→ *Refer to the separate PC manual.*

Standard transducers

Transducer	Type
PMT 301 - Portable Mini Transducer	PMT-089962
Standard MF (wide/medium beam) transducer	TDS-067538
MF (wide/narrow beam) transducer	TDN-081633
LF (wide beam) transducer	TDL-083420

Dunking transducers

Transducer	Type
MF narrow beam transducer	100-080377
MF wide beam transducer	100-082260
LF transducer	100-102880

RTD 333 - ROV Transducer

→ *Refer to the HPR 400S Instruction manual.*

DRAWINGS

Overview

This section contains some illustrations referred to in various sections in this manual. The illustrations are based on the original system drawings and wiring diagrams.

- The illustrations are not in scale.
- The original drawings are available in electronic format (AutoCAD) upon request.

The following drawings are included:

Cables and interconnections

- HPR 400 Transceiver Unit - internal connections (two pages) - see page 78.
- Portable transducer cable (without VRU) - see page 80.
- PMT 301 portable transducer cable - see page 81.

Standard transducers

- Transducer PMT 301 - outline dimensions, see page 82.
- Standard MF (Wide/medium beam) transducer - dimensions, see page 83.
- MF (wide/narrow beam) transducer - dimensions, see page 84.
- LF (wide beam) transducer, - dimensions, see page 84.

Dunking transducers

- MF narrow beam dunking transducer - dimensions, see page 85.
- MF wide beam dunking transducer - dimensions, see page 86.
- RTD 333 transducer, see page 89.

Miscellaneous

- Proposal of mounting an PMT 301, see page 87.
- Proposal of installing an PMT 301, see page 88.
- Bracket for HPR mini TD, see page 90.
- Brackets for tilt of PMT 300/301, see page 91.

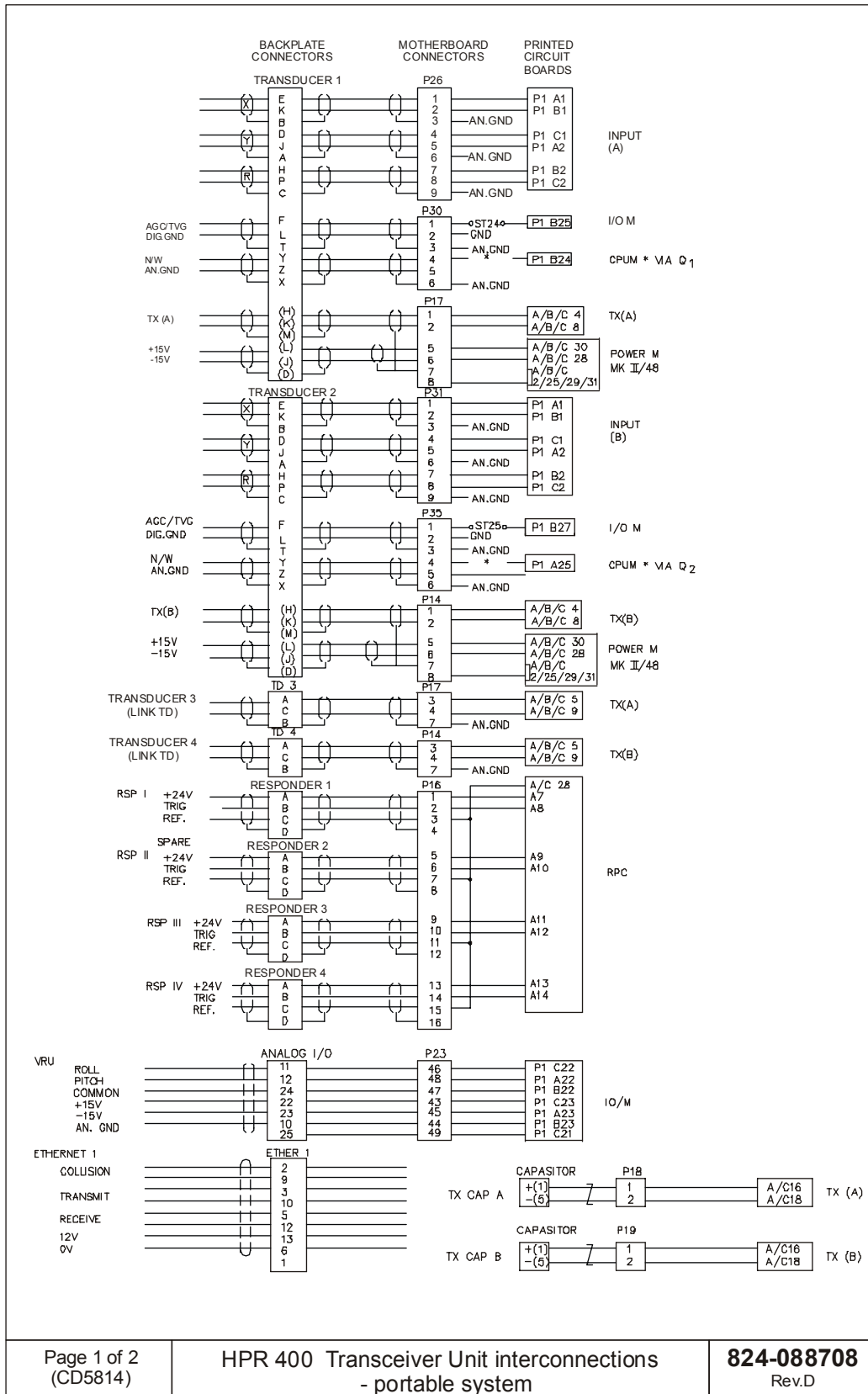

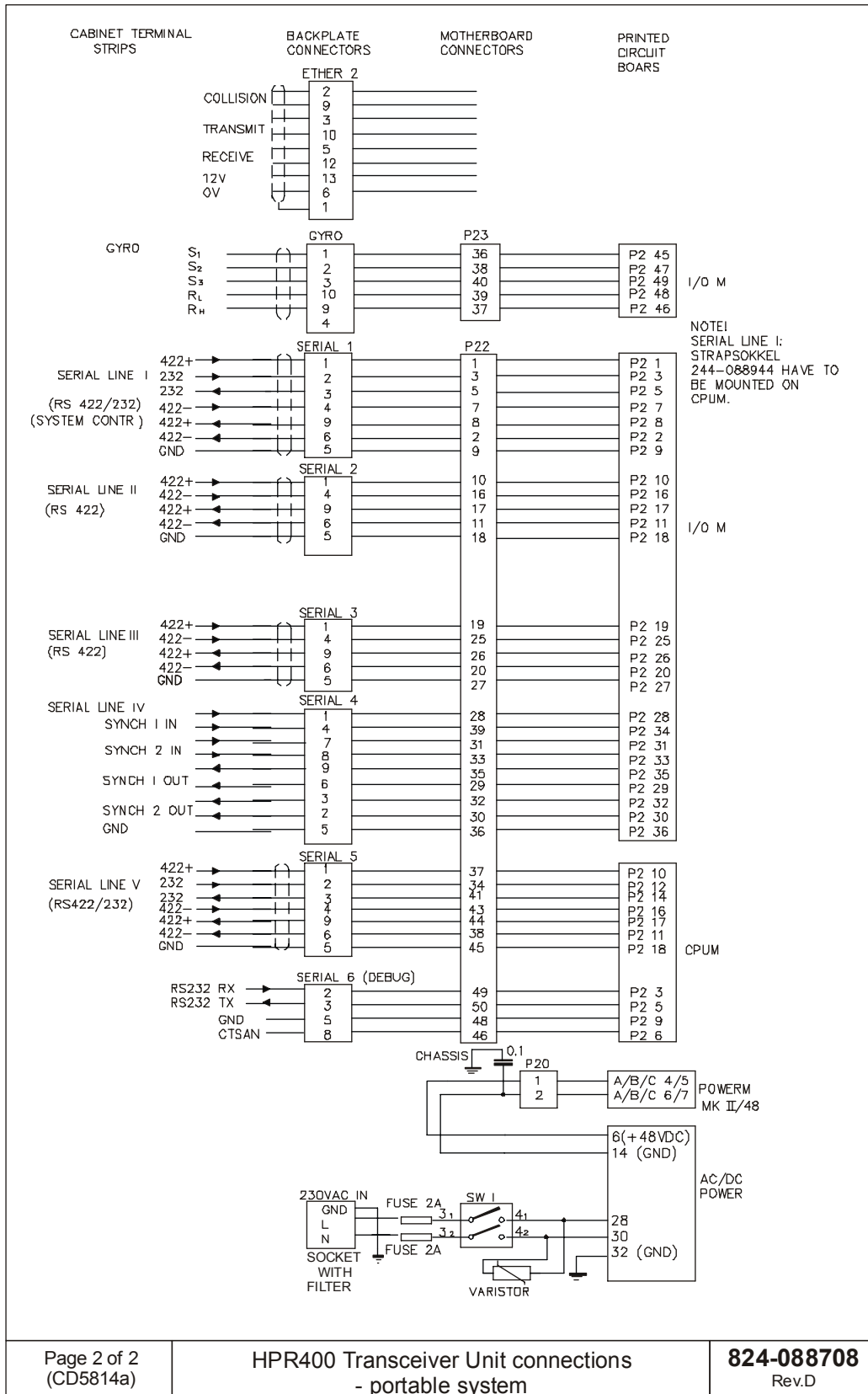

Kongsberg Simrad HPR 400 Portable system

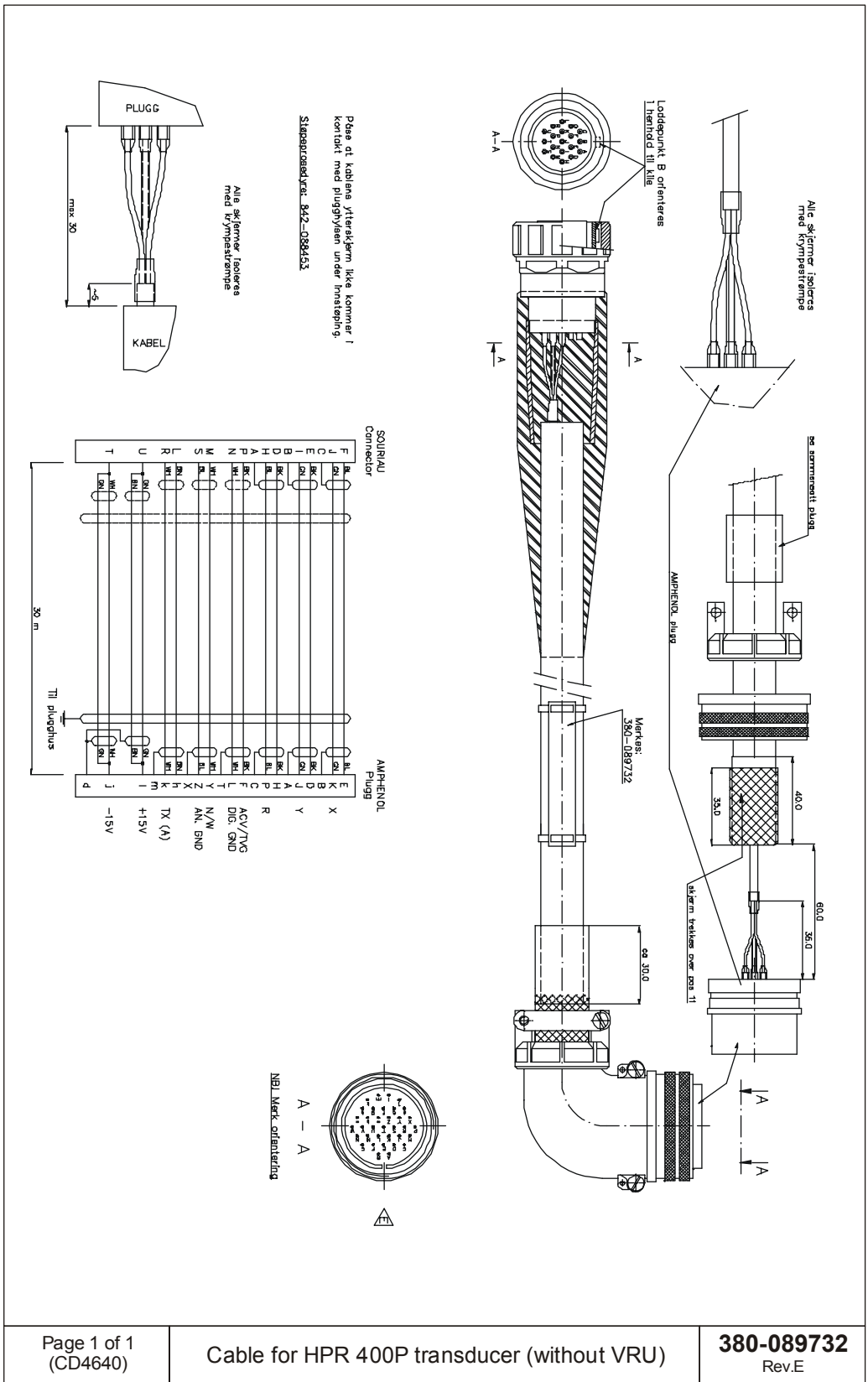

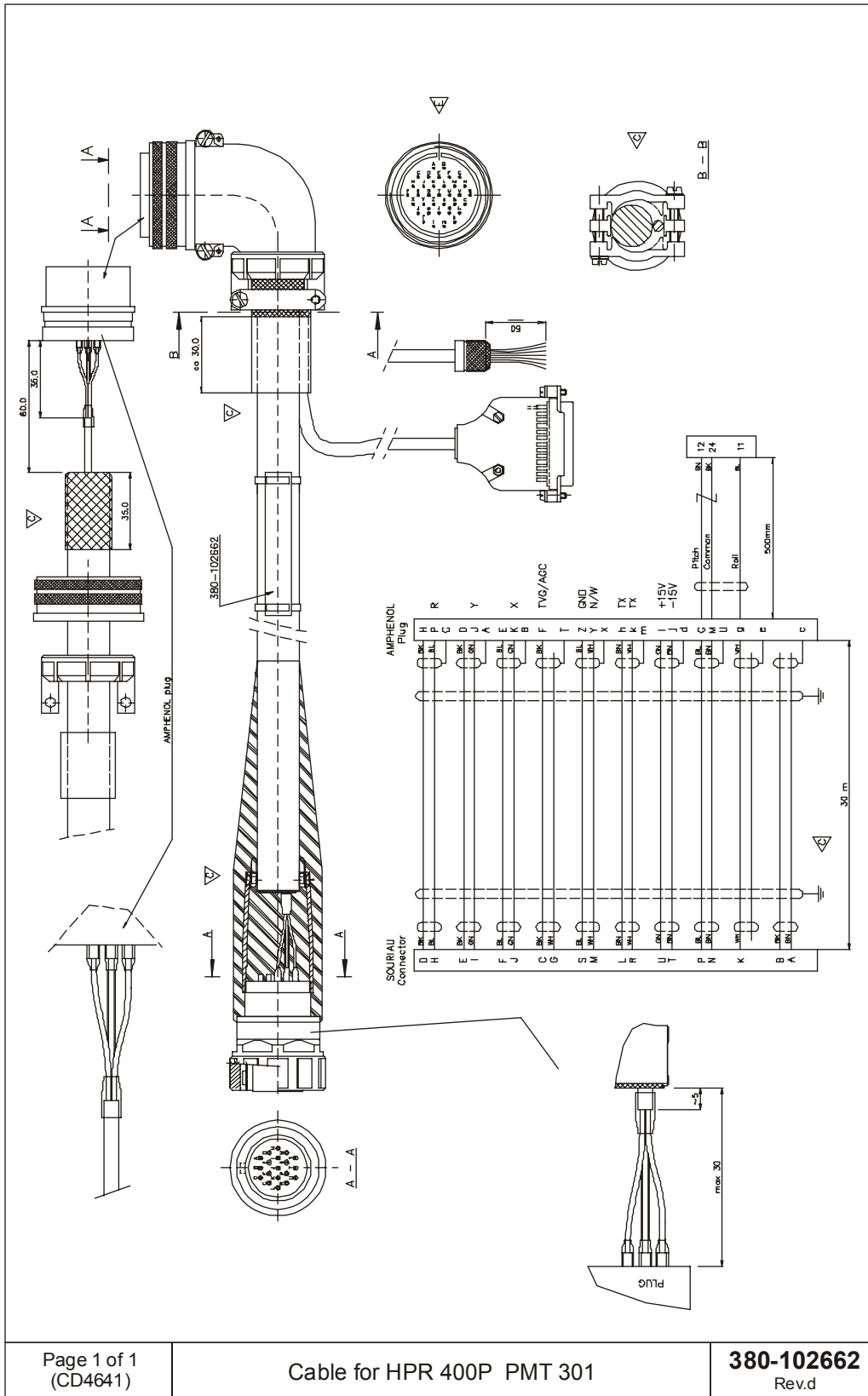

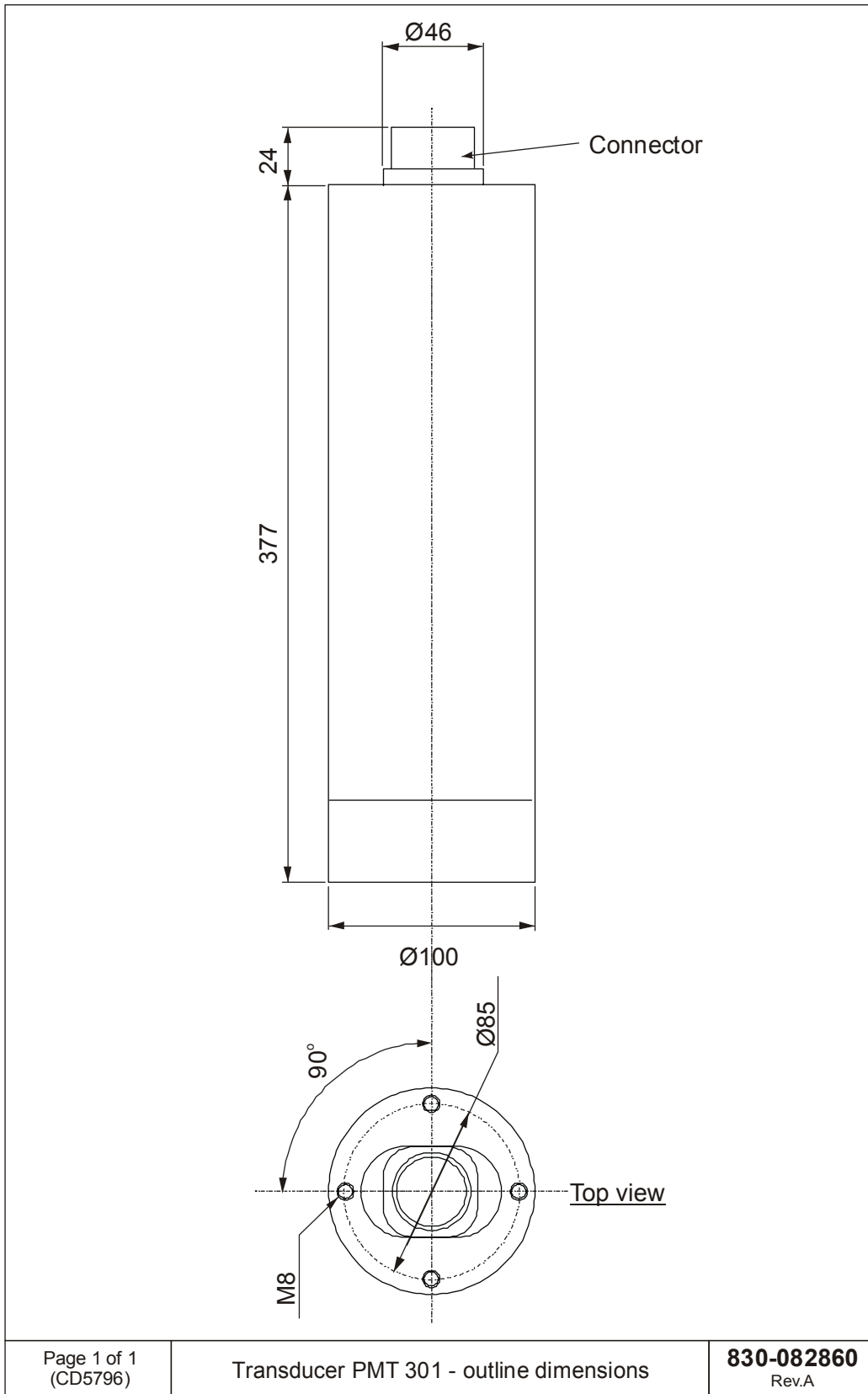

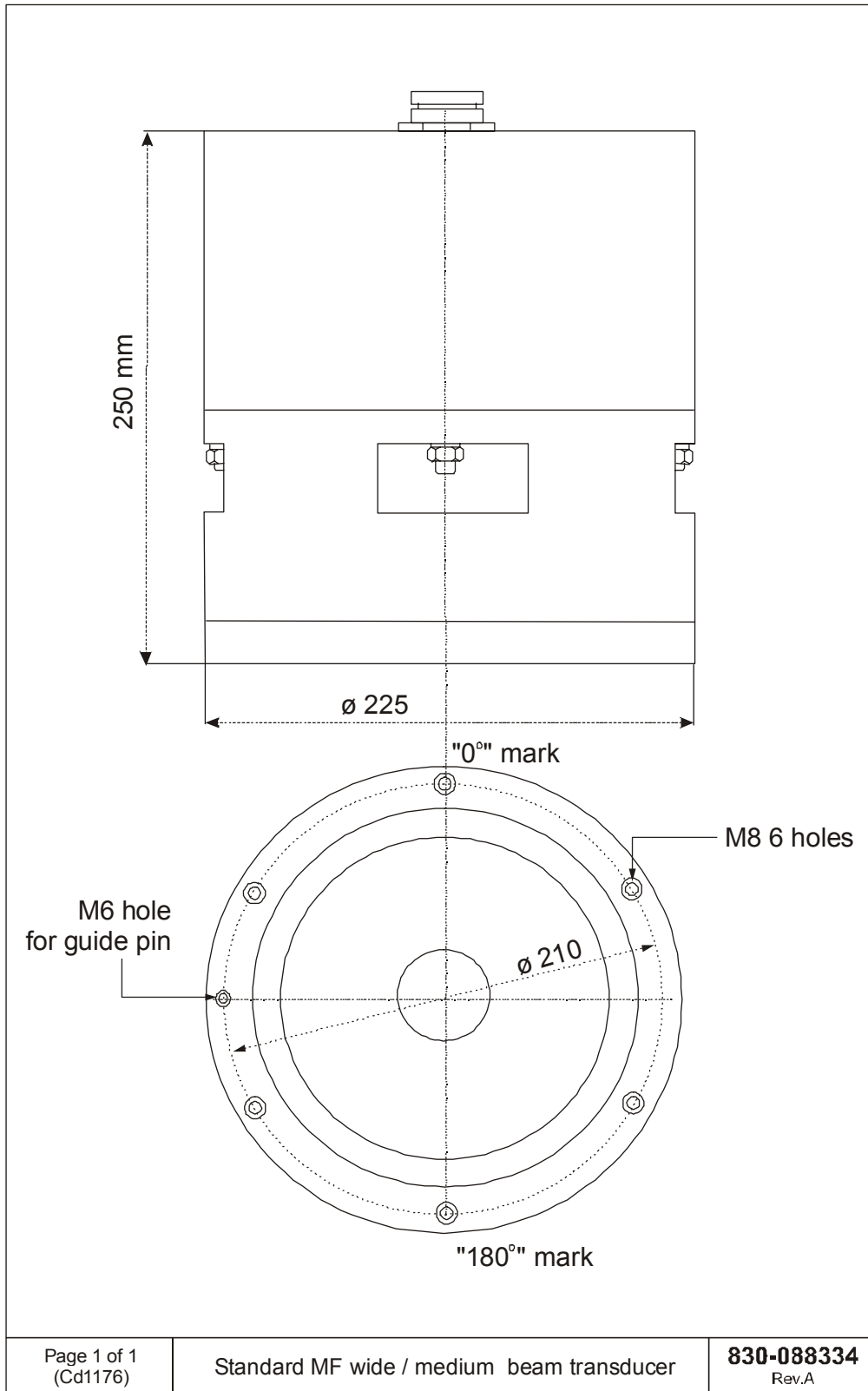

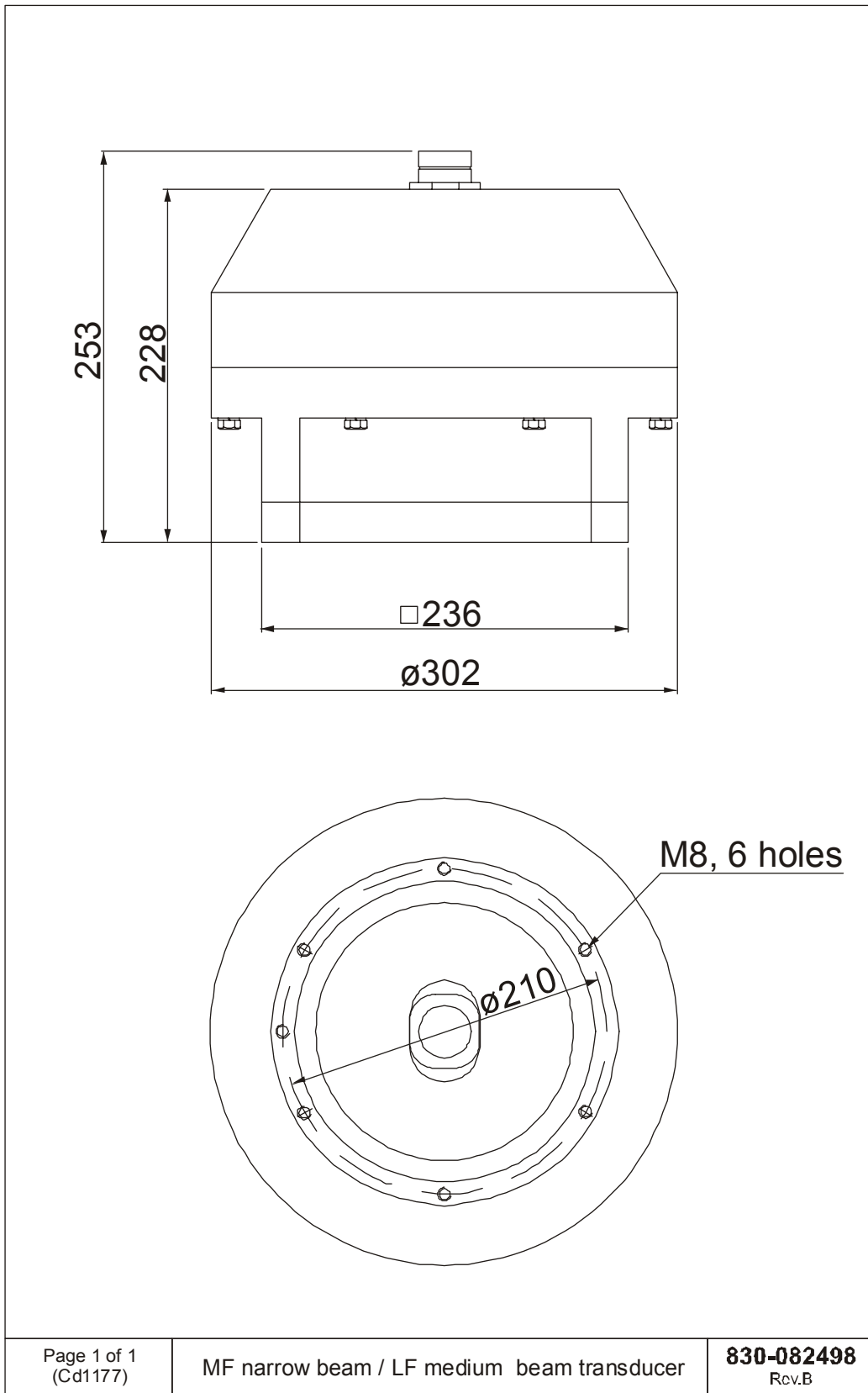

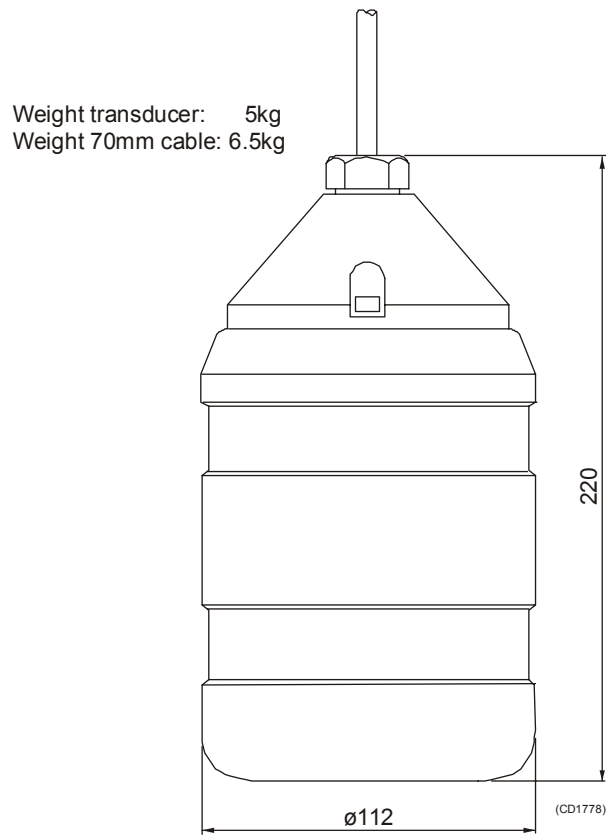
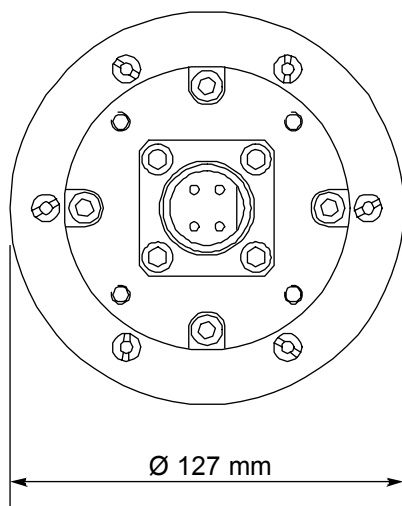

Figure 26 MF narrow beam dunking transducer - dimensions

(CD3966)



Weight: 3.5 kg (2.5 kg in water)

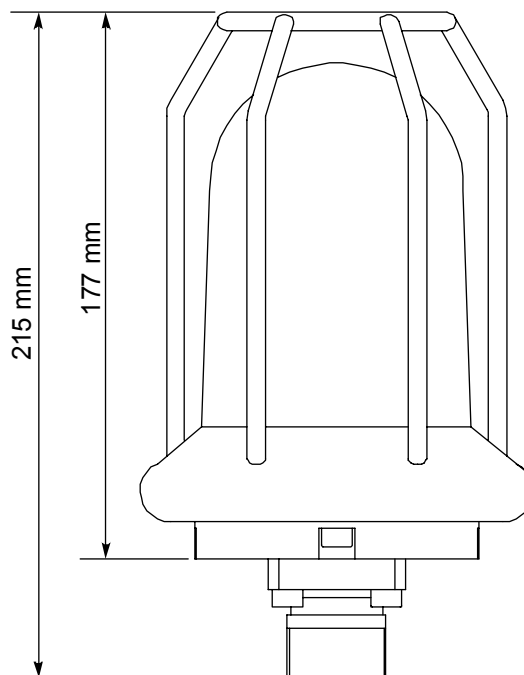
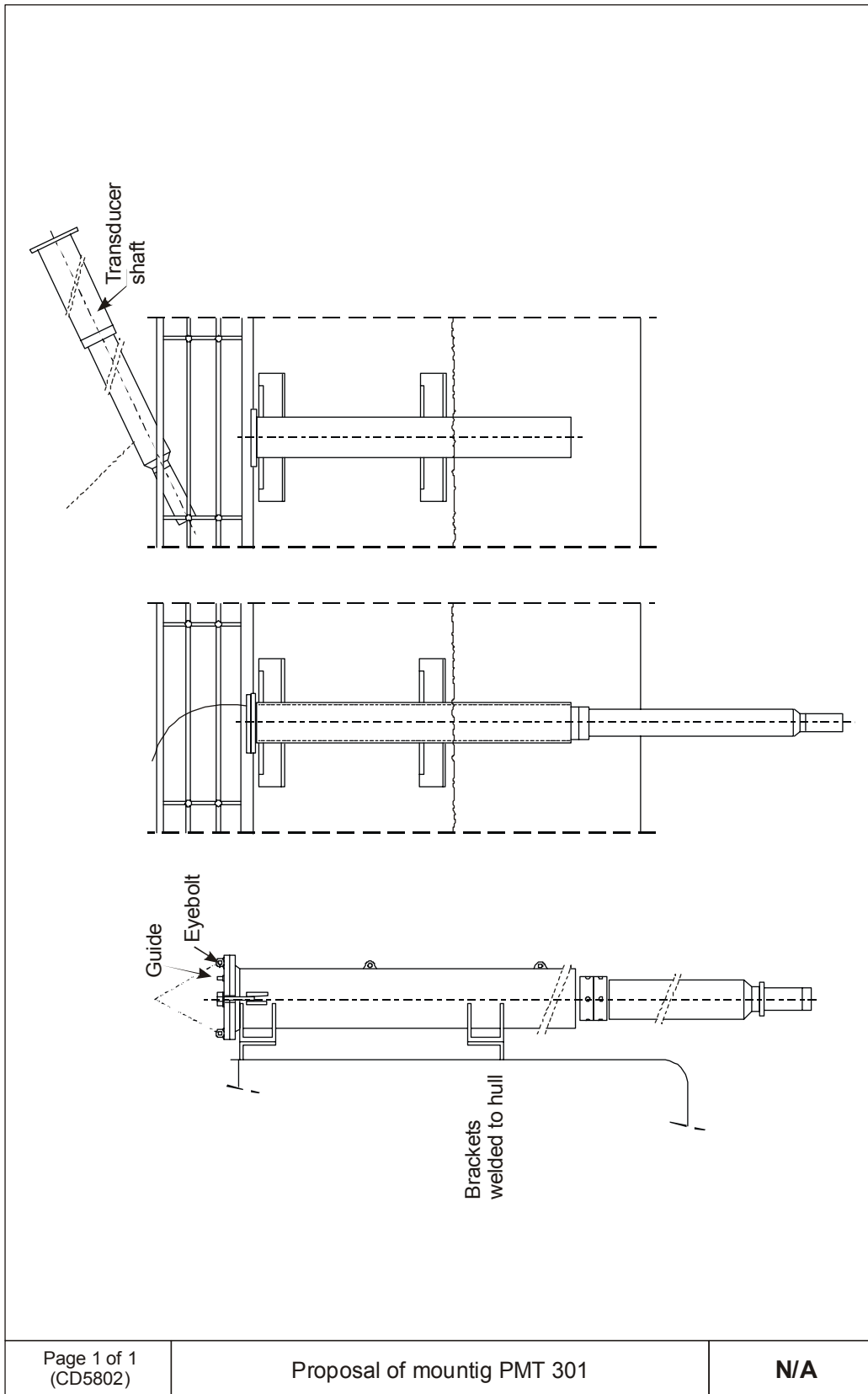
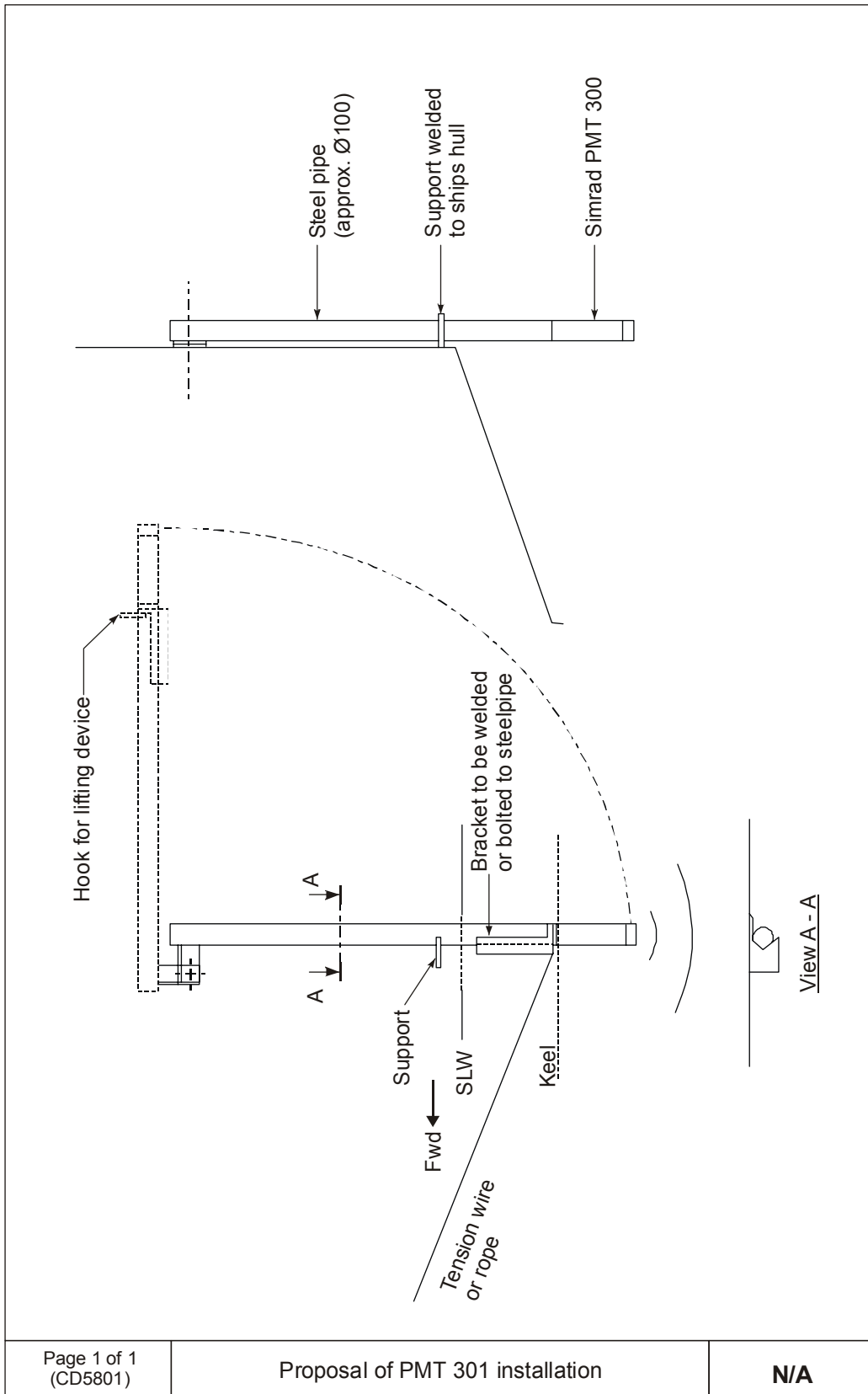
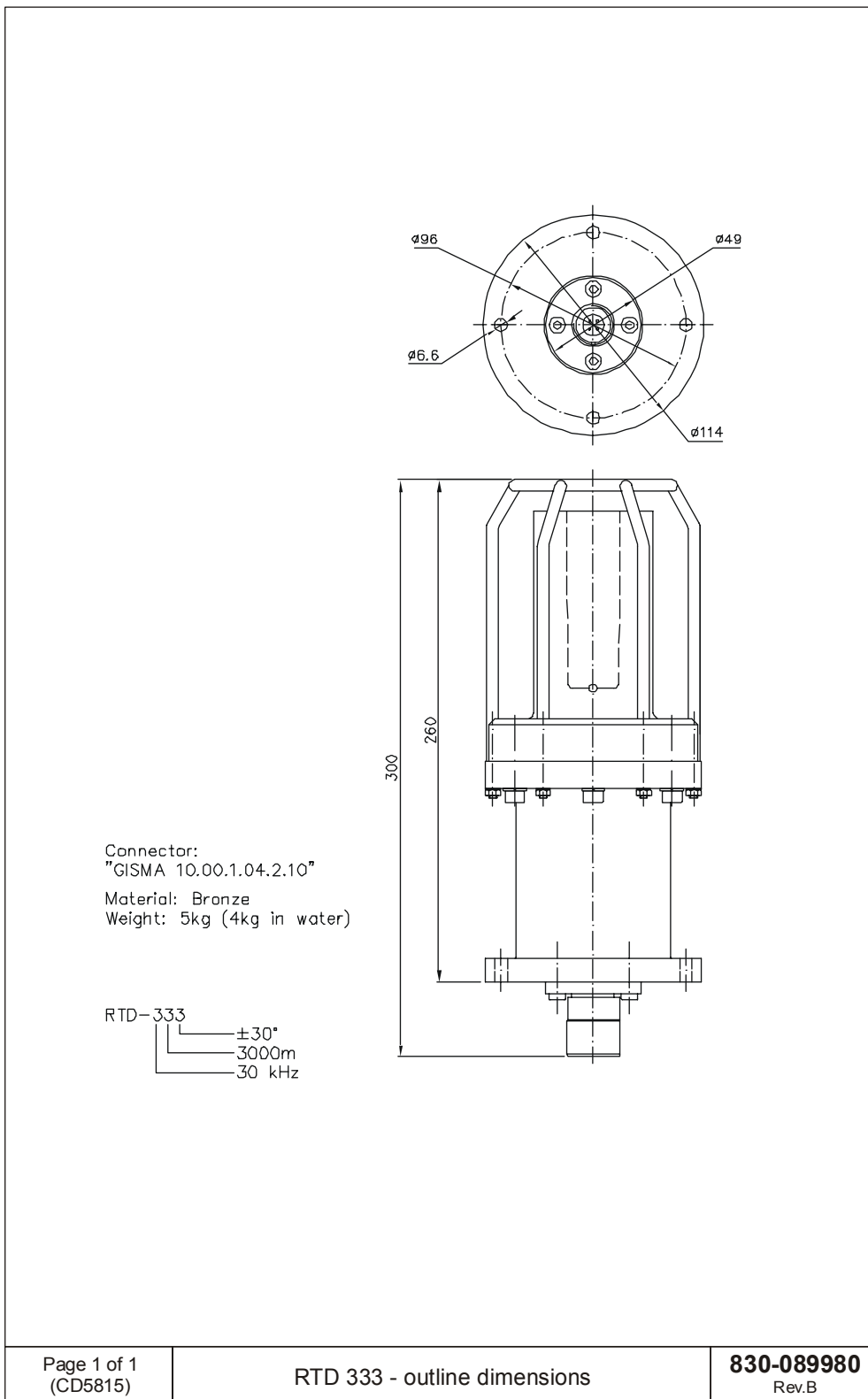

Figure 27 MF wide beam dunking transducer - dimensions





Page 1 of 1 (CD5801)	Proposal of PMT 301 installation	N/A
-------------------------	----------------------------------	-----



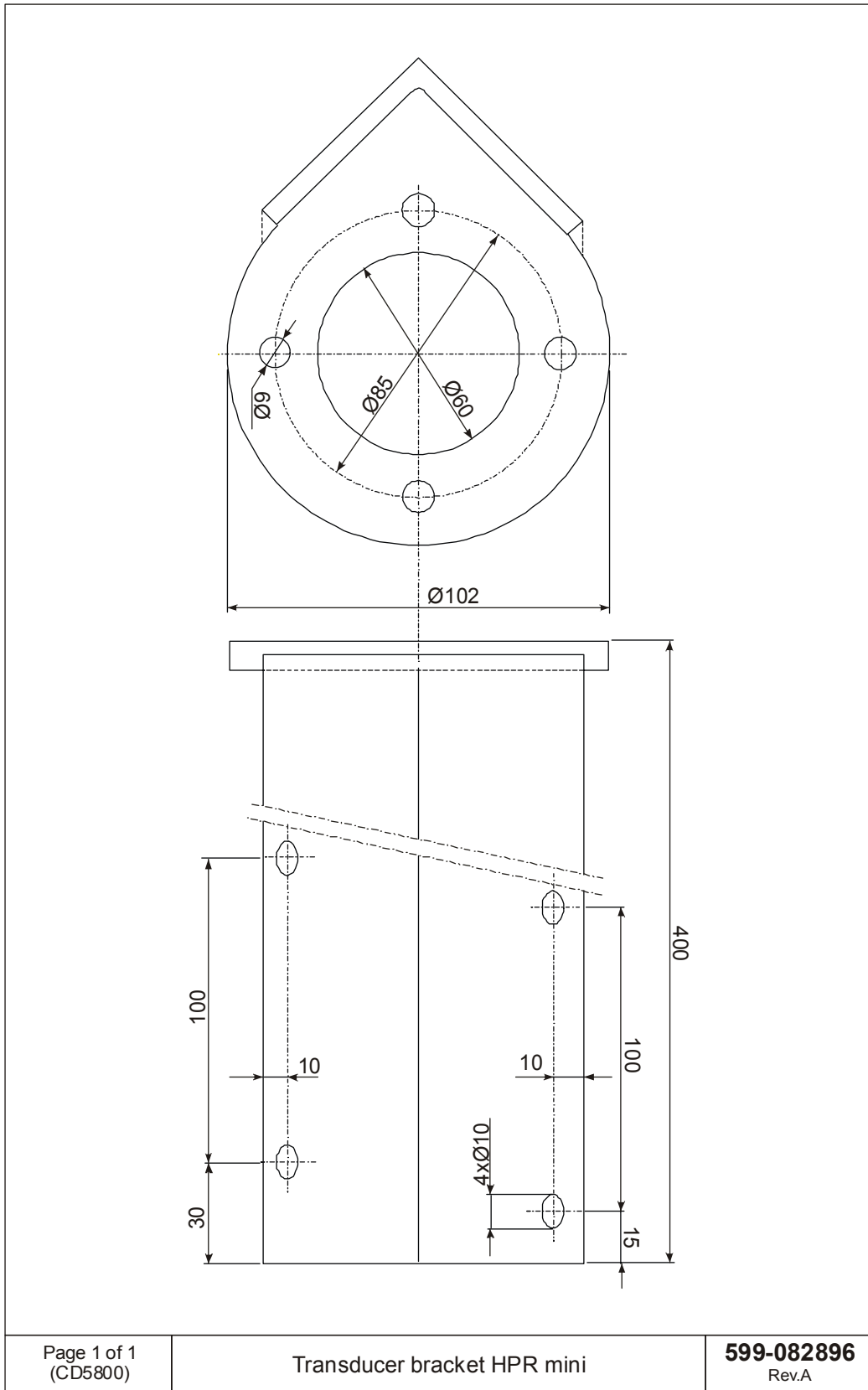

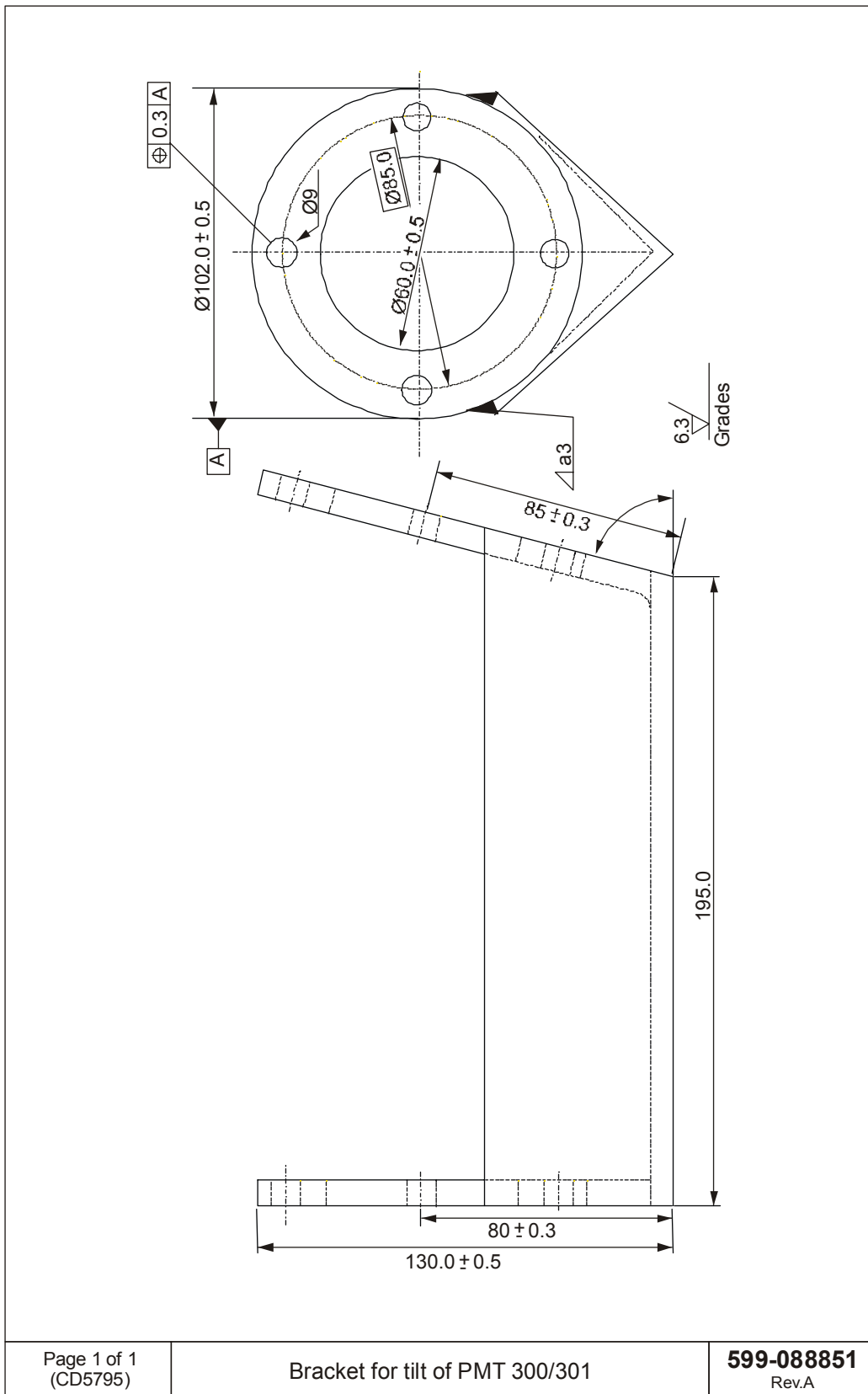

MAIN INDEX

The next pages presents the main index of this manual.

Numbers

230 Vac power supply, 15

A

AC, 42

AC power supply, 54

Board description, 54

Connections, 54

Electrical characteristics, 54

Fuses, 55

LEDs, 55

Purpose, 54

Socket – mounted components, 54

Technical specifications, 54

ADCM, 40, 42, 48

Alarm messages, 29

Analog Digital Converter, 40

Analogue digital converter, 48

Board description, 48

Connections, 49

Location and purpose, 48

Analogue I/O, 23

Analogue input/output, 17

APC 10 C computer, 21

APC 10 C computer, 16

APOS, 1, 7, 29

Available systems, 7

B

Backplane, 44

Connections, 44

Socket mounted components, 44

Block diagrams:

A/D Converter, 48

Digital Signal Processor (DSPM 50), 50

Transmitter circuit board, 52

Braided grounding cable, 15

C

Cable A, 19

Cable connections, 11

Cables, 14

Cables J, 19

Central Processing Unit, 40

Cleaning the transducers, 31

Com 1, 25

Com 2, 25

Com 3, 25

Com1, 18

Compact PC, 11, 69

Computer connectors, 18

Computer pin allocations, 25

LPT 1, 25

Connections, 16

Connectors, 14

Control processor unit

Board description, 56

Connections, 56

Links, 56

Test points, 56

Corrective maintenance, 28

CPUEX, 40, 56

CPUEX board, 57

LEDs, 57

Purpose, 56

CPUM, 42

D

DC, 42, 62

DC power supply board

Board description, 62

Connections, 63

Purpose, 62

Socket – mounted components, 63

Test points, 63

Design, 38

DGPS, 2

Digital Signal Processor, 40

Digital signal processor board, 50

Board description, 50

Connections, 50

LEDs, 51

Links, 51

Location, 50

Purpose, 50

Test points, 51

Dormant mode, 13

Drawings, 77

- Cables and interconnections, 77
- Dunking transducers, 77
- Miscellaneous, 77
- Standard transducers, 77

DSPM, 42

DSPM 50, 40, 50

Dunking transducer, 9, 12

Dunking transducers, 72

E

EMC, 15

ENET – M, 41

Ethernet, 41

Event messages, 29

External connections, 38

F

Fuses, 16, 36, 75

- Location, 36
- Replacement, 37

G

Getting started, 13

Gyro, 9, 23

Gyro compass, 12

Gyro input, 17

H

Heading reference, 68

HiPAP, 1

HPR, 1

- HPR 400 Narrow beam transducer, 64
- HPR 400 PMT 301, 64
- HPR 400 portable systems, 2
- HPR 400 portable unit, 67

- HPR 400 Standard transducer, 64
- HPR 400 Transceiver unit, 75
- HPR 400 transceiver Unit, 2
- HPR 400 transceiver unit, 38
- HPR 400P system, 2
- HPR 400S, 1
- HPR 408P, 2, 4, 5, 8
- HPR 410P, 2, 3, 7
- HPR 418P, 2, 3, 8

I

I/O, 58

Illustrations:

- 15-pin Delta connector, 23
- 25-pin Delta connector, 23, 26
- 9-pin Delta connector, 21, 25
- Connectors on the Transceiver Unit's rear panel, 16
- Error in the horizontal position, 65
- HPR 400 Transceiver Unit – rear side, 11
- HPR 400 Transceiver unit – functional block diagram, 40
- HPR 400 Transceiver Unit – internal layout, 43
- HPR 408 Portable system, 4, 5
- Portable cabinet, 6
- Portable cabinet – rear side, 6
- Portable computer's rear side, 18
- Responder connections, 20
- Responder connector, 24
- RPC board, 60
- Standard cables for a HPR 400 Portable system, 14
- Transducer 3/4 connector, 24
- VGA connector, 26

Input, 40

Input & Output, 41

Input/output board, 58

- 50-pin connector, 58
- Board description, 58
- Connections, 58
- Front mounted devices, 58
- Purpose, 58

INPUTM, 40

InputM, 46

- Connections, 46
- Purpose, 46
- Test points, 46

Installation and set – up, 10
 Interface cables, 11
 Internal layout, 42
 IOM, 41, 42

L

LBL, 1, 2
 LBL accuracy, 64
 LF, 1, 76
 LF (wide beam), 76
 LF transducer, 71, 73
 Line Replaceable Units, 32
 List of abbreviations, 1
 LPT1, 18
 LRUs, 32
 LSSBL, 1

M

Maintenance, 27
 Maintenance philosophy, 27
 MF, 1
 MF (wide/narrow beam), 76
 MF narrow beam, 76
 MF narrow beam transducer, 72
 MF transducer, 71
 MF wide beam transducer, 72, 76
 Modes, 13
 Motherboard, 41
 MPT, 1

N

N/A, 1
 Narrow beam transducer, 9
 Navigation, 39

O

Operation, 8
 Operator Station, 11
 Operator station, 2, 6, 7, 28, 69

P

Parallel, 22
 Parallel input, 17
 PMT 301, 9
 PMT 301 , 76
 PMT 301 – Portable Mini Transducer, 70
 PMT 301 Portable Mini Transducer, 12
 PMT – 301 portable transducer cable, 77
 Portable transducer cable, 77
 Power supply, 38
 Preventive maintenance, 27

R

Range capabilities, 66
 Rear connectors, 16
 Rear panel, 16
 Removal of circuit boards, 32
 Removal of the backplane, 34
 Replacement of circuit boards, 35
 Replacement of the backplane, 35
 Replacement of the transducer, 31
 Replacement of transceiver unit parts, 32
 Responder, 12
 Responder 1, 17
 Responder 1 – 4, 24
 Responder 2, 17
 Responder 3, 17
 Responder 4, 17
 Responder controller board, 60
 Board description, 60
 Connections, 61
 Front mounted devices, 60
 Fuses, 61
 LED, 61

Links, 61
 Socket – mounted components, 60
 Switches, 60
 Test points, 61
 Responder trigger pulses, 60
 Roll and pitch reference, 68
 ROV, 1
 RPC, 60
 RPC board, 60
 RS 422 Serial line cable, 14
 RTD 333, 76
 RTD 333 – ROV Transducer, 73

S

Serial 1, 21
 Serial 2, 21
 Serial 3, 21
 Serial 4, 22
 Serial 5, 22
 Serial 6, 22
 Serial line 1, 16
 Serial line 2, 16
 Serial line 3, 16
 Serial line 4, 16
 Serial line 5, 16
 Serial line 6, 17
 Serial line cables, 19
 Serial line to external computer, 12
 Set – up, 11
 Software, 33
 Spare parts, 74
 Portable PC, 76
 SSBL, 1, 2
 SSBL Accuracy, 64
 Standard cables, 19
 Standard MF, 76
 Standard MF transducer, 71
 Standard transducer, 9
 Standby mode, 13

Startup, 8
 Static electricity, 28
 Syncro, 23
 System description, 2
 System set – up, 11
 System units, 2

T

Technical specifications, 64
 Telemetry, 39
 Test points, 59
 Theory of operation, 39
 Tools, 28
 TP, 1
 Transceiver Uni, 42
 Transceiver Unit, 6, 7, 11, 16, 21, 32, 68
 Transceiver unit, 27, 28
 Transceiver Unit – internal connections, 77
 Transceiver Unit connectors, 16
 Transceiver Unit pin allocations, 21
 Transducer, 31
 Transducer 1, 17
 Transducer 2, 17
 Transducer 3, 17
 Transducer 4, 17
 Transducer frequency combinations, 69
 Transducers, 8, 12, 70
 Transducers 1 and 2, 24
 Transducers 3 and 4, 24
 Transmitter, 40
 Transmitter board, 52
 Board description, 52
 Connections, 53
 Front mounted devices, 52
 Links, 53
 Purpose, 52
 Socket – mounted components, 52
 Switches, 53
 Test points, 53
 TU, 1
 TXM, 40, 42, 52

V

Vertical reference sensor, 12

Vertical Reference Unit, 9

VGA, 26

VGA monitor, 18

VRU, 9, 12

Blank page

Kongsberg Simrad HPR 400P
Instruction Manual

Kongsberg Simrad HPR 400P
Instruction Manual

Kongsberg Simrad HPR 400P
Instruction Manual

Kongsberg Simrad HPR 400P
Instruction Manual

Kongsberg Simrad HPR 400P
Instruction Manual

